

Micro-Power Voltage Detector

1 General Description

The RT9818 is a micro-power voltage detector designed to supervise the power supply voltage levels for microprocessors (μ P) or digital systems. It provides internally fixed threshold levels with 0.1V increments, ranging from 1.2V to 5V, covering most digital applications. The device features a low supply current of 3 μ A. The RT9818 performs supervisory function by sending out a reset signal whenever the VDD voltage falls below a preset threshold level. This reset signal persists until VDD recovers and surpasses the threshold level, at which point the reset signal is released after a certain delay time. The RT9818 is available in SC-82, SC-70-3, SOT-23-3, SOT-23-5, and SOT-89 packages. The recommended junction temperature range is -40°C to 125°C , and the ambient temperature range is -40°C to 85°C .

2 Applications

- Desktop/Notebook Computers
- Critical μ P and μ C Power Monitoring
- Portable/Battery-Powered Equipment
- Controllers

3 Marking Information

For marking information, contact our sales representative directly or through a Richtek distributor located in your area.

4 Features

- Internally Fixed Threshold from 1.2V to 5V in 0.1V Step
- $\pm 1.5\%$ High Accuracy
- 3 μ A Low Supply Current
- No External Components Required
- Quick Reset within 20 μ s
- Built-In Recovery Delay Options: 0ms, 55ms, 220ms, 450ms
- 0.9V Low Functional Supply Voltage
- N-Channel Open-Drain Output
- Available in Small SC-82, SC-70-3, SOT-23-3, SOT-23-5, and SOT-89 Packages

5 Ordering Information

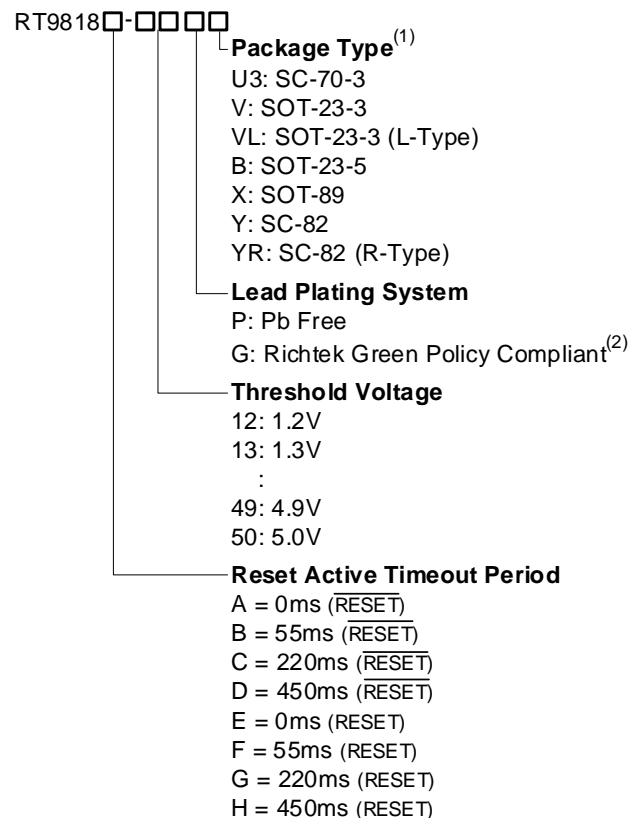

Note 1.

- Marked with ⁽¹⁾ indicated: Compatible with the current requirements of IPC/JEDEC J-STD-020.
- Marked with ⁽²⁾ indicated: Richtek products are Richtek Green Policy compliant.

Table of Contents

1	General Description.....	1	16	Outline Dimension.....	12
2	Applications	1	16.1	SC-70-3.....	12
3	Marking Information.....	1	16.2	SC-82.....	13
4	Features.....	1	16.3	SOT-23-3.....	14
5	Ordering Information	1	16.4	SOT-23-5.....	15
6	Pin Configuration.....	3	16.5	SOT-89.....	16
7	Functional Pin Description.....	3	17	Footprint Information	17
8	Functional Block Diagram.....	3	17.1	SC-70-3.....	17
9	Absolute Maximum Ratings.....	4	17.2	SC-82.....	18
10	Recommended Operating Conditions.....	4	17.3	SOT-23-3.....	19
11	Electrical Characteristics	5	17.4	SOT-23-5.....	20
12	Typical Application Circuit	6	17.5	SOT-89.....	21
13	Timing Diagram.....	6	18	Packing Information	22
14	Typical Operating Characteristics	7	18.1	Tape and Reel Data.....	22
15	Application Information.....	11	18.2	Tape and Reel Packing	27
15.1	Multiple Supplies.....	11	18.3	Packing Material Anti-ESD Property.....	32
15.2	Benefits of Highly Accurate Reset Threshold	11	19	Datasheet Revision History	33

6 Pin Configuration

(TOP VIEW)

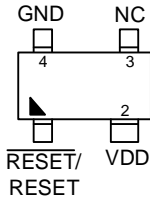

SC-82

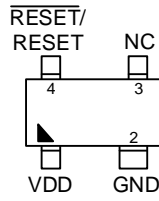

SC-82 (R-Type)

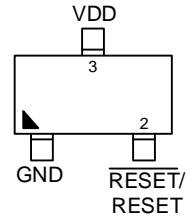

SC-70-3

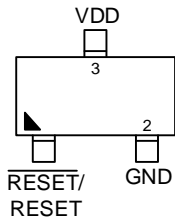

SOT-23-3

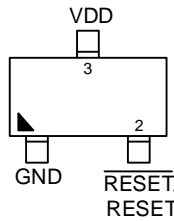

SOT-23-3 (L-Type)

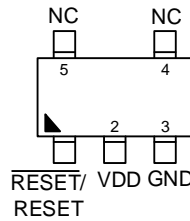

SOT-23-5

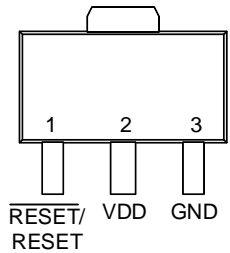

SOT-89

7 Functional Pin Description

Pin Name	Pin Function
GND	Ground.
$\overline{\text{RESET}}$	Active low open-drain reset output.
RESET	Active high open-drain reset output.
VDD	Supply voltage input pin

8 Functional Block Diagram

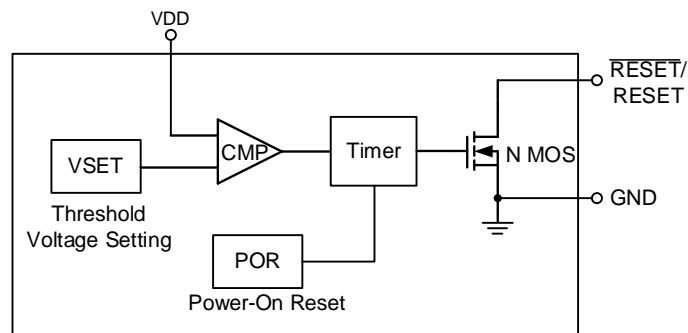

9 Absolute Maximum Ratings

(Note 2)

- Supply Input Voltage, V_{DD} ----- -0.3V to 6V
- All Other Inputs----- -0.3V to 6V
- Input Current, I_{DD} ----- 20mA
- Power Dissipation, P_D @ $T_A = 25^\circ\text{C}$
 - SC-70 / SC-82----- 0.25W
 - SOT-23-3----- 0.4W
 - SOT-23-5----- 0.4W
 - SOT-89----- 0.55W
- Package Thermal Resistance (Note 3)
 - SC-70 / SC-82, θ_{JA} ----- 400°C/W
 - SOT-23-3, θ_{JA} ----- 250°C/W
 - SOT-23-5, θ_{JA} ----- 250°C/W
 - SOT-89, θ_{JA} ----- 180°C/W
- Lead Temperature (Soldering, 10 sec.)----- 260°C
- Storage Temperature Range----- -65°C to 150°C
- ESD Susceptibility (Note 4)
 - HBM (Human Body Model)----- 2kV

Note 2. Stresses beyond those listed under “Absolute Maximum Ratings” may cause permanent damage to the device. These are stress ratings only, and functional operation of the device at these or any other conditions beyond those indicated in the operational sections of the specifications is not implied. Exposure to absolute maximum rating conditions may affect device reliability.

Note 3. θ_{JA} is measured under natural convection (still air) at $T_A = 25^\circ\text{C}$ with the component mounted on a low effective-thermal-conductivity single-layer test board on a JEDEC 51-3 thermal measurement standard.

Note 4. Devices are ESD sensitive. Handling precautions are recommended.

10 Recommended Operating Conditions

(Note 5)

- Junction Temperature Range----- -40°C to 125°C
- Ambient Temperature Range----- -40°C to 85°C

Note 5. The device is not guaranteed to function outside its operating conditions.

11 Electrical Characteristics

(V_{DD} = 3.3V, T_A = 25°C, unless otherwise specified.)

Parameter	Symbol	Test Conditions	Min	Typ	Max	Unit	
Static Characteristics							
Operating V _{DD} Range	V _{DD}		0.9	--	6	V	
Supply Current	I _{DD}	V _{TH} = 3V, V _{DD} = 4.5V, T _A = 27°C	--	3	8	μA	
Reset Threshold	V _{TH}	T _A = 27°C	--	1.2 to 5	--	V	
Threshold Voltage Accuracy	V _{TH_ACC}	T _A = 27°C	-1.5	--	1.5	%	
V _{DD} Drop to Reset Delay	t _{RDLY}	Drop = V _{TH} - 125mV	--	20	--	μs	
Reset Active Time Out Period	t _{RP}	V _{DD} ≥ 1.02 x V _{TH}	RT9818A/E	--	0	--	ms
			RT9818B/F	35	55	75	
			RT9818C/G	143	220	297	
			RT9818D/H	292	450	608	
RESET Output Voltage Low (Note 6)	V _{OL}	V _{DD} > V _{TH(MAX)} , I _{SINK} = 3.5mA V _{TH_MIN} ≥ 3V	--	--	0.4	V	
Hysteresis Width	V _{HYS}		--	0.01V _{TH}	0.016V _{TH}	V	

Note 6. The voltage V_{OL} can be calculated using $V_{OL} = V_{DD} - I_r \times R$. Where R is the pull-up resistor and I_r is the current flowing through the pull-up resistor. For typical application (R = 100kΩ), V_{OL} is less than 0.2V.

12 Typical Application Circuit

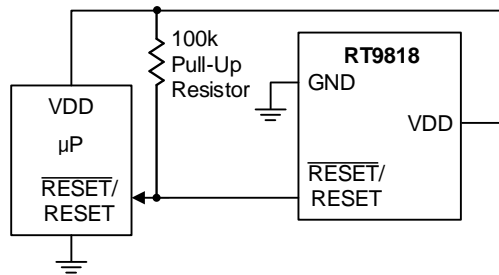

13 Timing Diagram

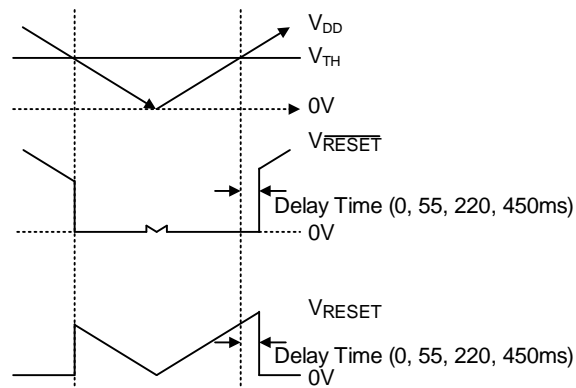

14 Typical Operating Characteristics

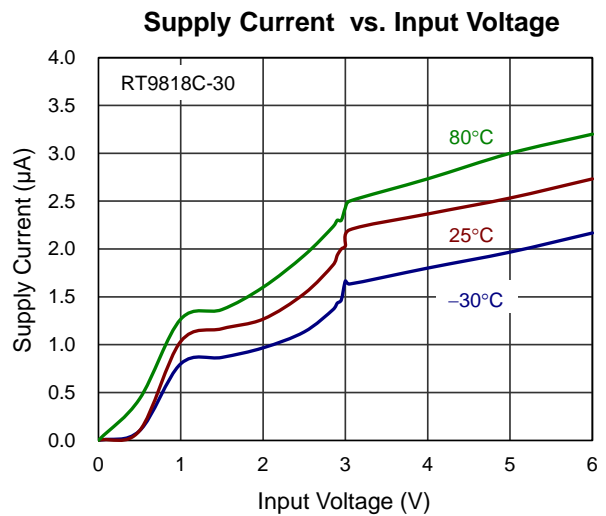
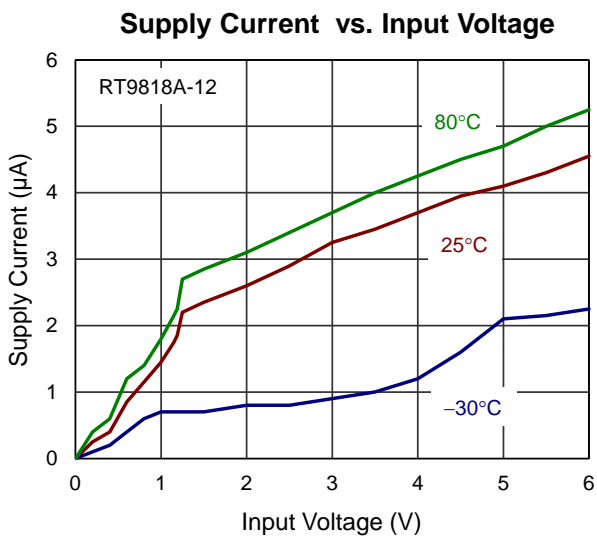
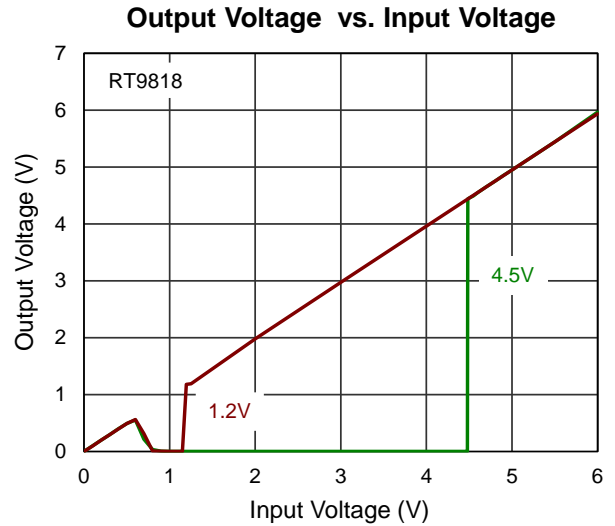
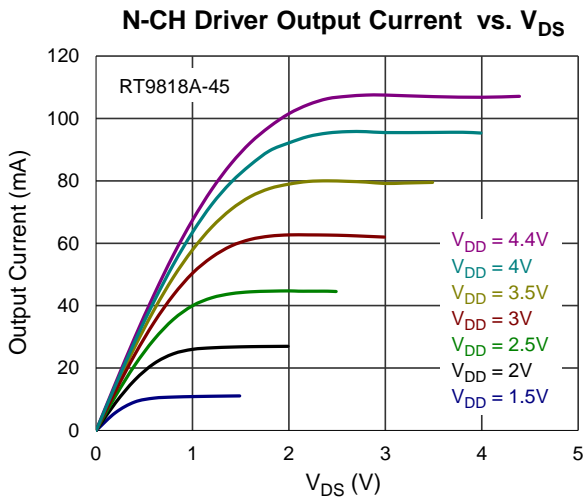
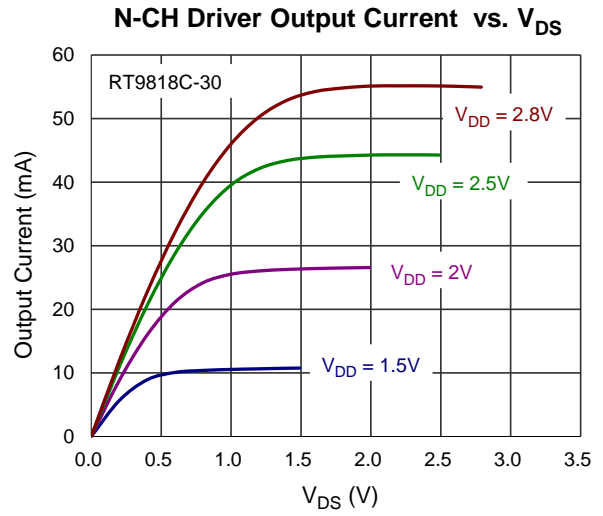
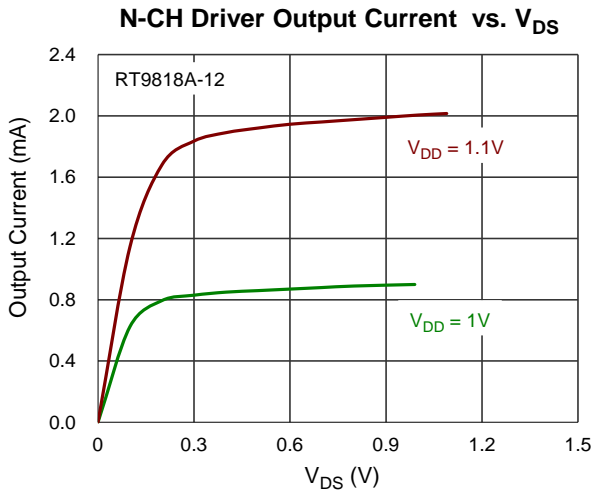

Supply Current vs. Input Voltage

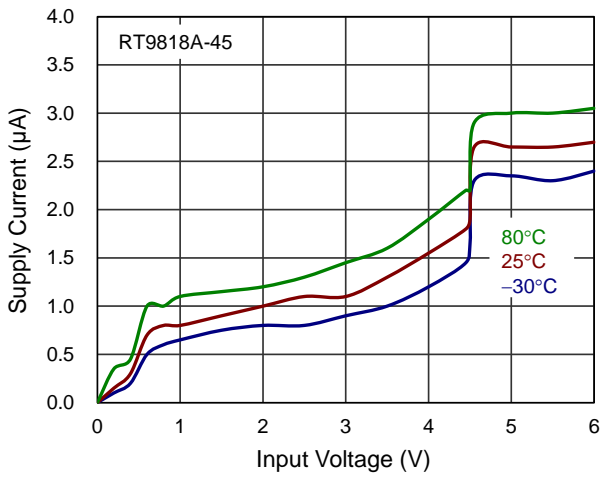

Power-Down Reset Delay vs. Temperature

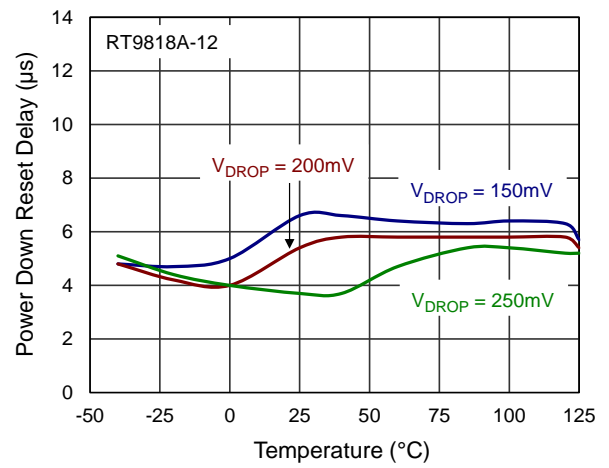

Power-Down Reset Delay vs. Temperature

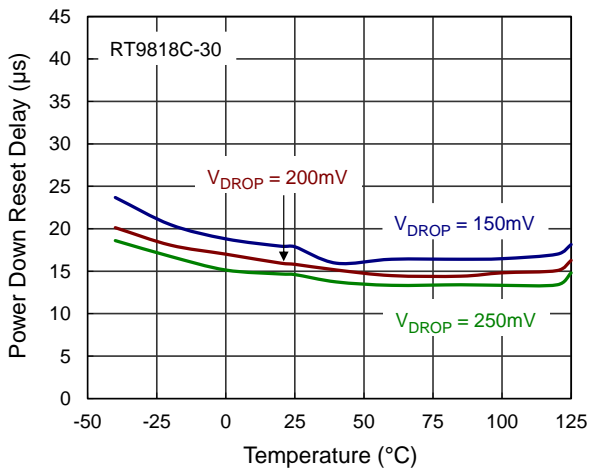

Power-Down Reset Delay vs. Temperature

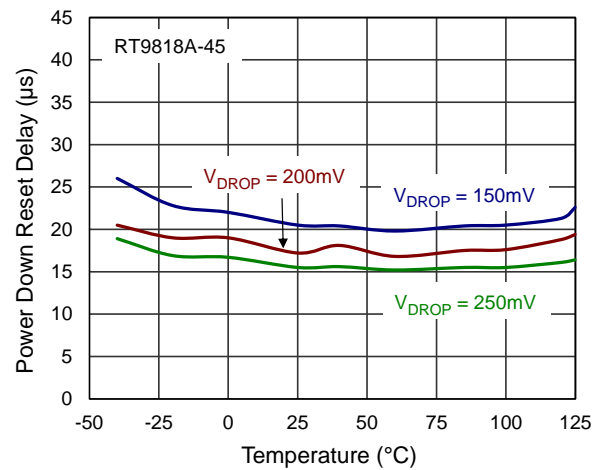

Reset Threshold Deviation vs. Temperature

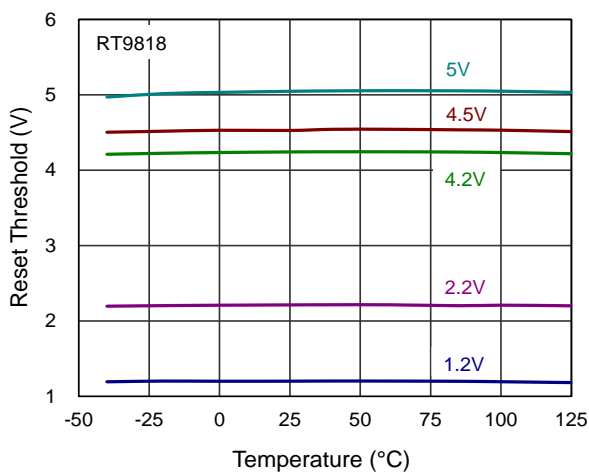

N-CH Driver Sink Current vs. Input Voltage

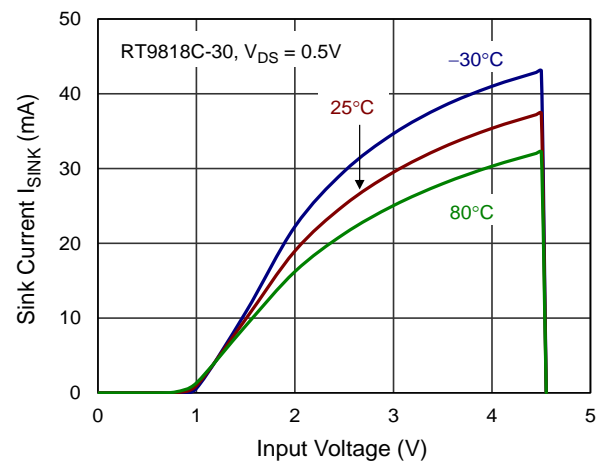

N-CH Driver Sink Current vs. Input Voltage

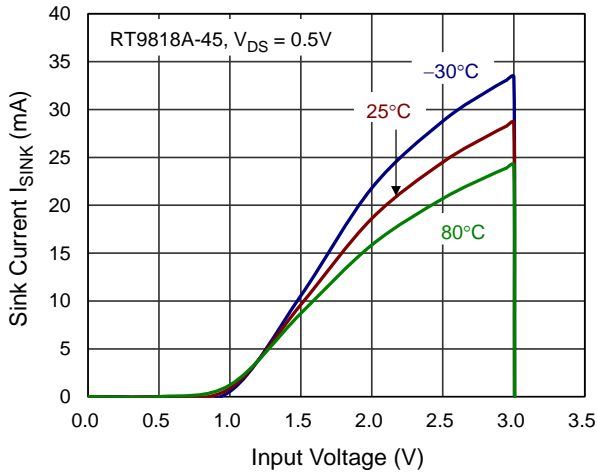

Power-Up Reset Time-Out vs. Temperature

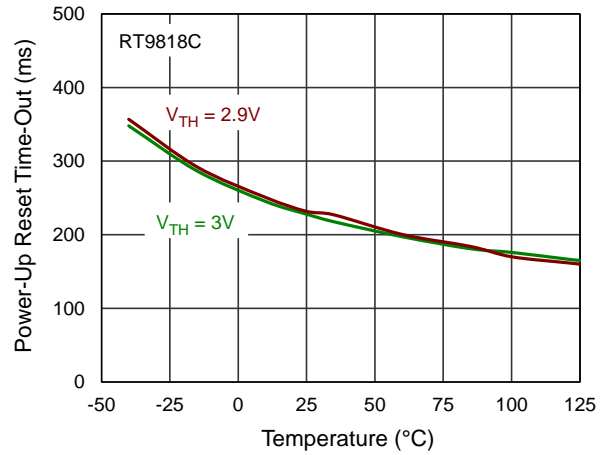

Power-Up Reset Time-Out vs. Temperature

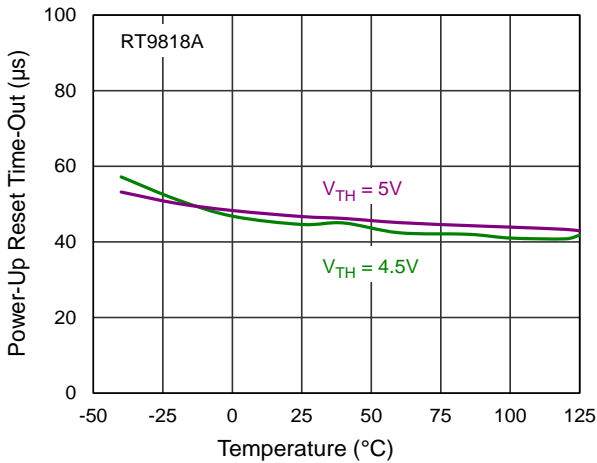

Output Delay Time vs. Load Capacitance

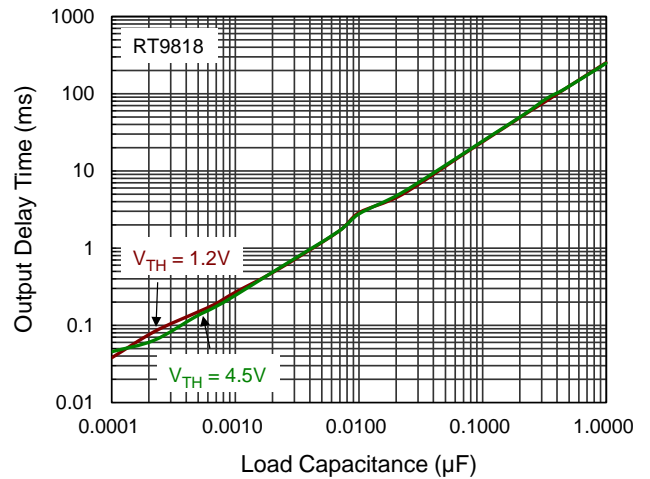

N-CH Driver Output Current vs. V_{DS}

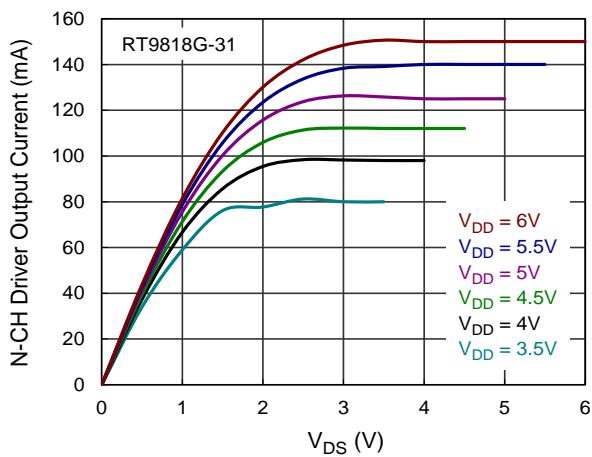

N-CH Driver Output Current vs. Input Voltage

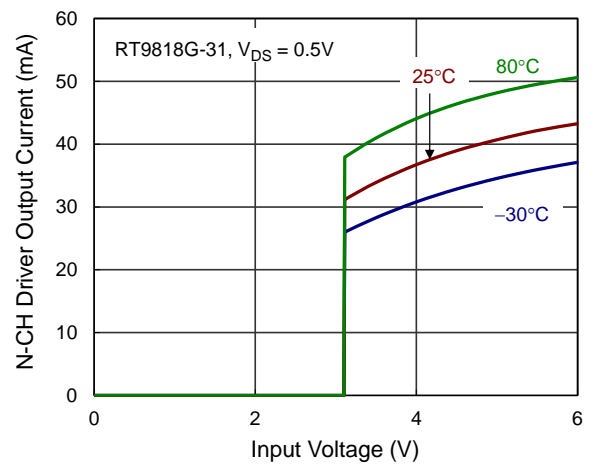

Power-Down Reset Time-Out vs. Temperature

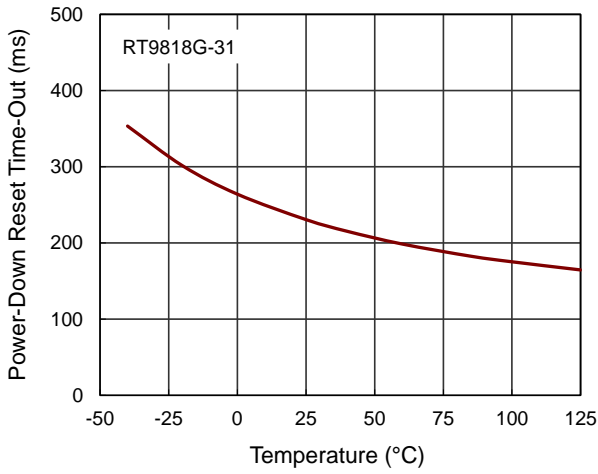

Output Voltage vs. Input Voltage

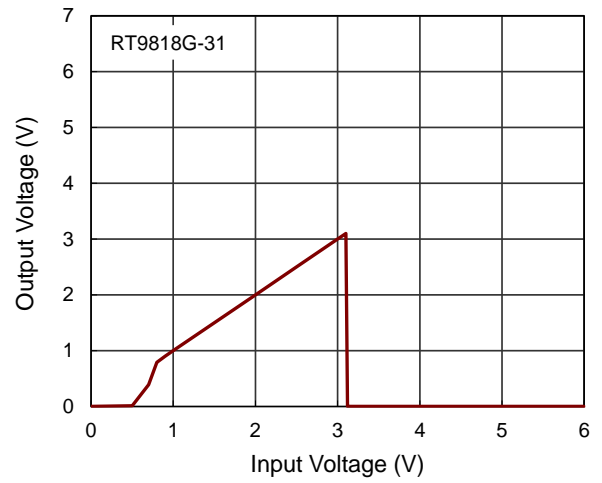

Power-Down Reset Time-Out vs. Temperature

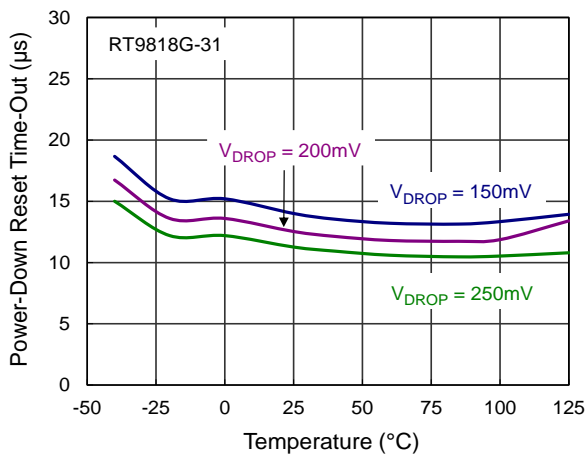

Threshold Voltage vs. Temperature

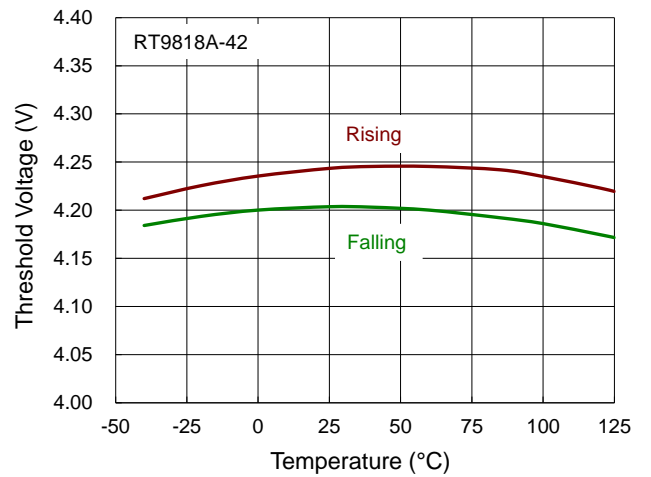

Threshold Voltage vs. Temperature

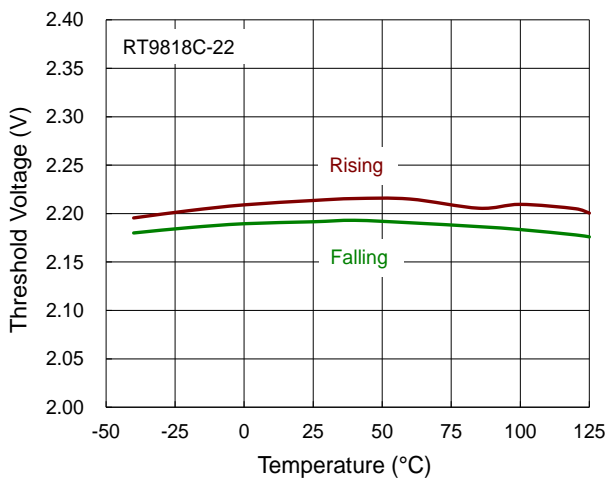

15 Application Information

[\(Note 7\)](#)

15.1 Multiple Supplies

The pull-up resistor connected to the RT9818 is tied to the supply voltage being monitored at the IC's VDD pin. However, some systems may use the open-drain output to level-shift from the monitored supply to reset circuitry powered by a different supply.

15.2 Benefits of Highly Accurate Reset Threshold

Most μ P supervisor ICs have reset threshold voltages set between 1% and 1.5% below the nominal supply voltage. This ensures that a reset will not occur within 1% of the nominal supply, but will occur when the supply voltage drops 1.5% below nominal.

Note 7. The information provided in this section is for reference only. The customer is solely responsible for designing, validating, and testing any applications incorporating Richtek's product(s). The customer is also responsible for applicable standards and any safety, security, or other requirements.

16 Outline Dimension

16.1 SC-70-3

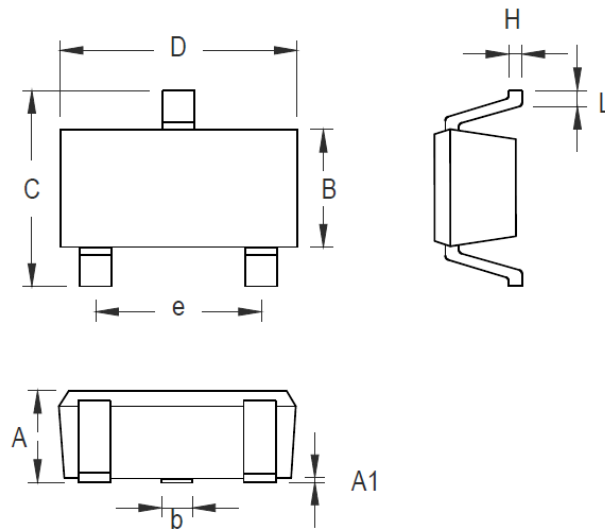

Symbol	Dimensions In Millimeters		Dimensions In Inches	
	Min	Max	Min	Max
A	0.800	1.100	0.031	0.044
A1	0.000	0.100	0.000	0.004
B	1.150	1.350	0.045	0.054
b	0.150	0.400	0.006	0.016
C	1.800	2.450	0.071	0.096
D	1.800	2.250	0.071	0.089
e	1.300		0.051	
H	0.080	0.260	0.003	0.010
L	0.210	0.460	0.008	0.018

SC-70-3 Surface Mount Package

16.2 SC-82

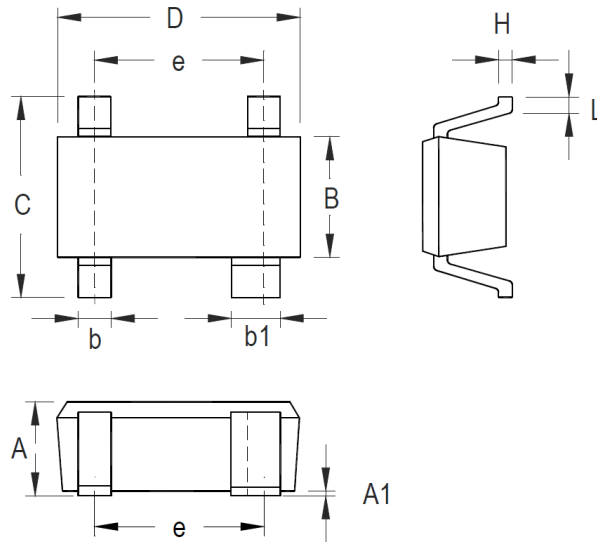

Symbol	Dimensions In Millimeters		Dimensions In Inches	
	Min	Max	Min	Max
A	0.800	1.100	0.031	0.043
A1	0.000	0.100	0.000	0.004
B	1.150	1.350	0.045	0.053
b	0.150	0.400	0.006	0.016
b1	0.350	0.500	0.014	0.020
C	1.800	2.450	0.071	0.096
D	1.800	2.200	0.071	0.087
e	1.300		0.051	
H	0.080	0.260	0.003	0.010
L	0.200	0.460	0.008	0.018

SC-82 Surface Mount Package

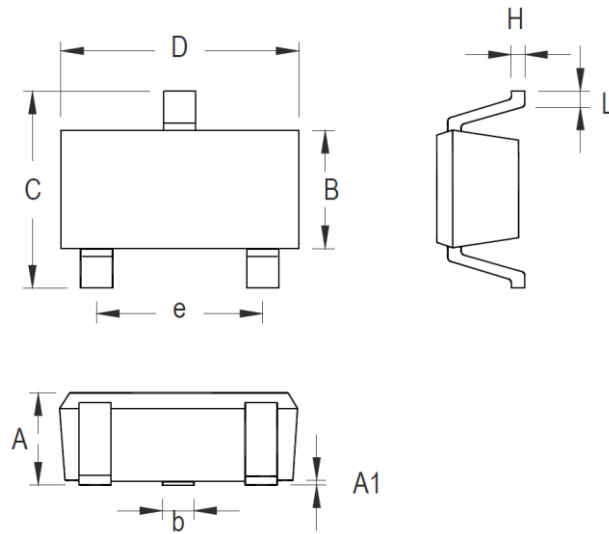

Symbol	Dimensions In Millimeters		Dimensions In Inches	
	Min	Max	Min	Max
A	0.889	1.295	0.035	0.051
A1	0.000	0.152	0.000	0.006
B	1.397	1.803	0.055	0.071
b	0.356	0.508	0.014	0.020
C	2.591	2.997	0.102	0.118
D	2.692	3.099	0.106	0.122
e	1.803	2.007	0.071	0.079
H	0.080	0.254	0.003	0.010
L	0.300	0.610	0.012	0.024

SOT-23-3 Surface Mount Package

16.4 SOT-23-5

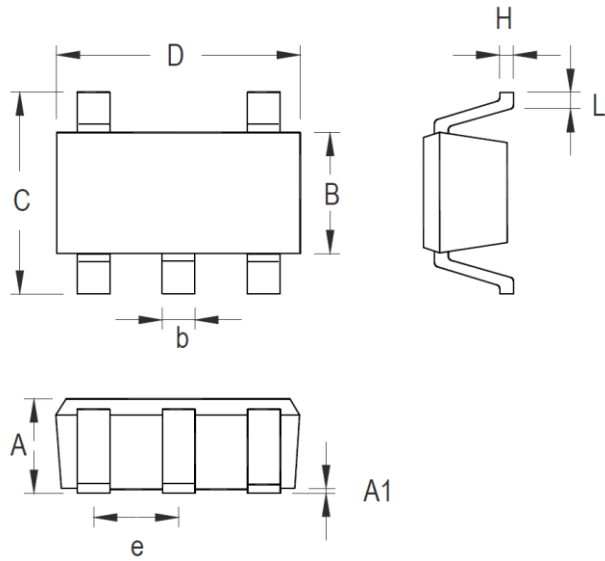

Symbol	Dimensions In Millimeters		Dimensions In Inches	
	Min	Max	Min	Max
A	0.889	1.295	0.035	0.051
A1	0.000	0.152	0.000	0.006
B	1.397	1.803	0.055	0.071
b	0.356	0.559	0.014	0.022
C	2.591	2.997	0.102	0.118
D	2.692	3.099	0.106	0.122
e	0.838	1.041	0.033	0.041
H	0.080	0.254	0.003	0.010
L	0.300	0.610	0.012	0.024

SOT-23-5 Surface Mount Package

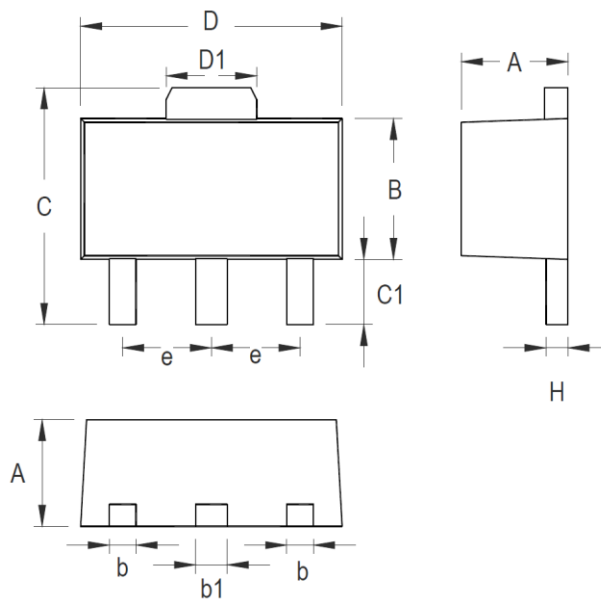

Symbol	Dimensions In Millimeters		Dimensions In Inches	
	Min	Max	Min	Max
A	1.397	1.600	0.055	0.063
b	0.356	0.483	0.014	0.019
B	2.388	2.591	0.094	0.102
b1	0.406	0.533	0.016	0.021
C	3.937	4.242	0.155	0.167
C1	0.787	1.194	0.031	0.047
D	4.394	4.597	0.173	0.181
D1	1.397	1.753	0.055	0.069
e	1.448	1.549	0.057	0.061
H	0.356	0.432	0.014	0.017

3-Lead SOT-89 Surface Mount Package

17 Footprint Information

17.1 SC-70-3

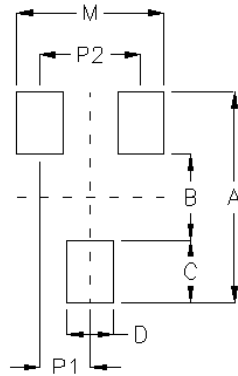

Package	Number of Pin	Footprint Dimension (mm)							Tolerance
		P1	P2	A	B	C	D	M	
SC-70-3	3	0.65	1.30	2.70	1.10	0.80	0.60	1.90	±0.10

17.2 SC-82

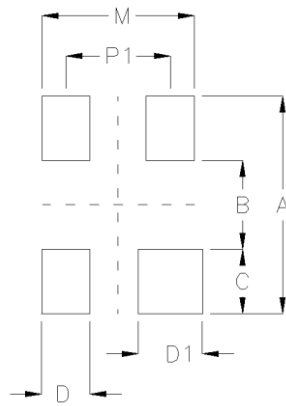

Package	Number of Pin	Footprint Dimension (mm)							Tolerance
		P1	A	B	C	D	D1	M	
SC-82	4	1.30	2.70	1.10	0.80	0.60	0.80	1.90	±0.10

17.3 SOT-23-3

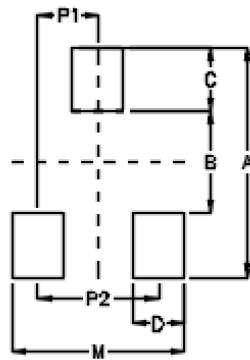

Package	Number of Pin	Footprint Dimension (mm)							Tolerance
		P1	P2	A	B	C	D	M	
TSOT-23/SOT-23	3	0.95	1.90	3.60	1.60	1.00	0.80	2.70	±0.10

17.4 SOT-23-5

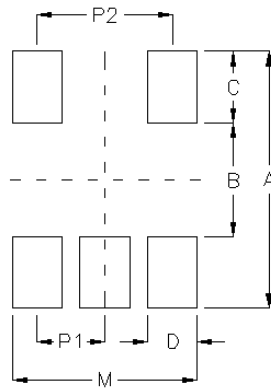

Package	Number of Pin	Footprint Dimension (mm)							Tolerance
		P1	P2	A	B	C	D	M	
TSOT-25/TSOT-25(FC)/SOT-25	5	0.95	1.90	3.60	1.60	1.00	0.70	2.60	±0.10

17.5 SOT-89

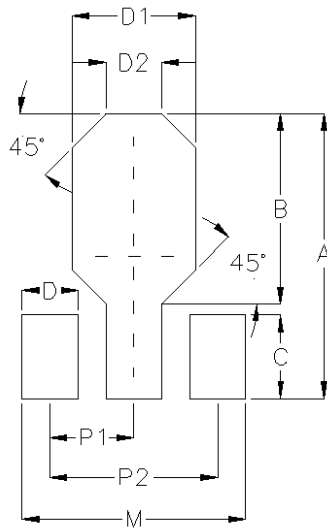

Package	Number of Pin	Footprint Dimension (mm)									Tolerance
		P1	P2	A	B	C	D	D1	D2	M	
SOT-89	3	1.50	3.00	5.10	3.40	1.50	1.00	2.20	1.00	4.00	±0.10

18 Packing Information

18.1 Tape and Reel Data

18.1.1 SC-70-3

SC-70-3:

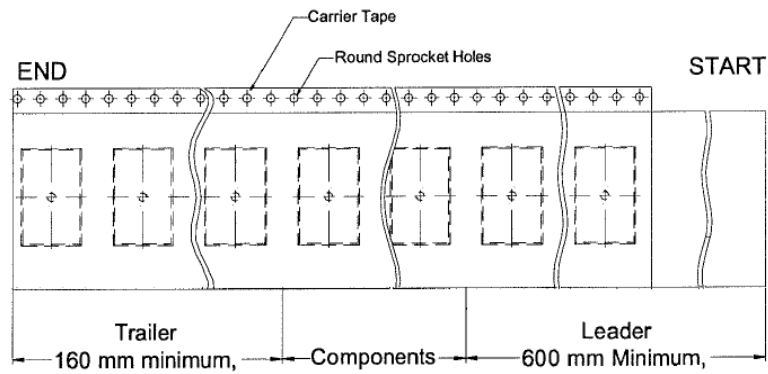
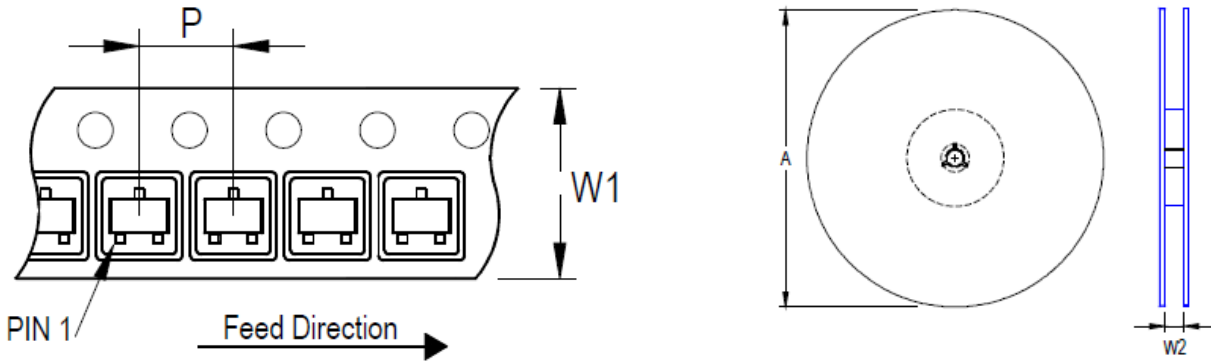

Package Type	Tape Size (W1) (mm)	Pocket Pitch (P) (mm)	Reel Size (A)		Units per Reel	Trailer (mm)	Leader (mm)	Reel Width (W2) Min./Max. (mm)
			(mm)	(in)				
SC-70-3	8	4	180	7	3,000	160	600	8.4/9.9

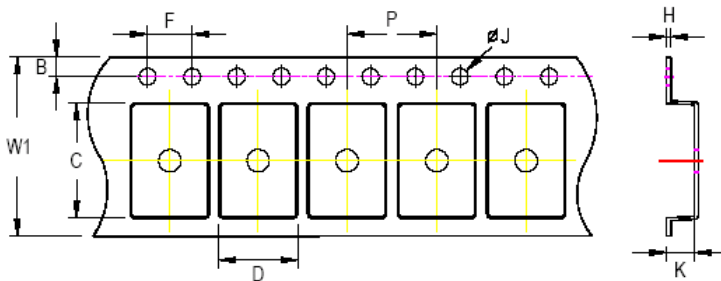

C, D, and K are determined by component size. The clearance between the components and the cavity is as follows:
 - For 8mm carrier tape: 0.5mm max.

Tape Size	W1		P		B		F		ØJ		K		H
	Max.	Min.	Max.	Min.	Max.	Min.	Max.	Min.	Max.	Min.	Max.	Max.	
8mm	8.3mm	3.9mm	4.1mm	1.65mm	1.85mm	3.9mm	4.1mm	1.5mm	1.6mm	1.1mm	1.3mm	0.6mm	

18.1.2 SC-82

SC-82:

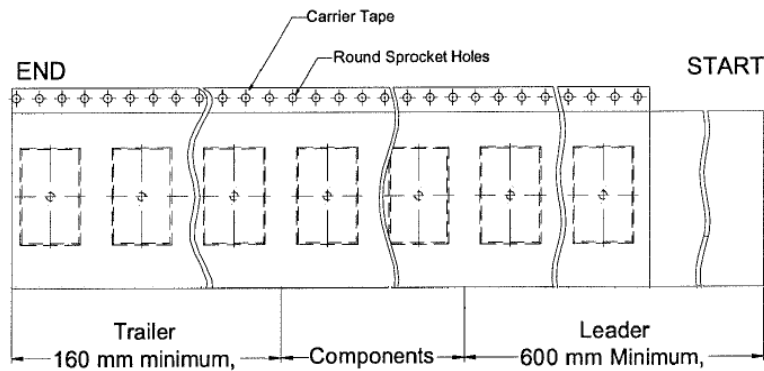
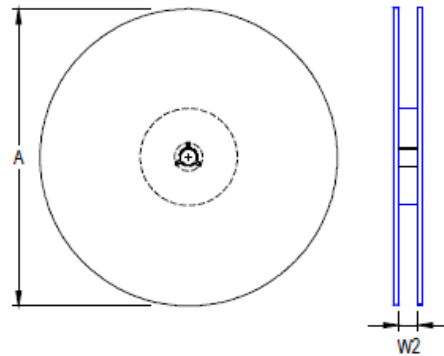
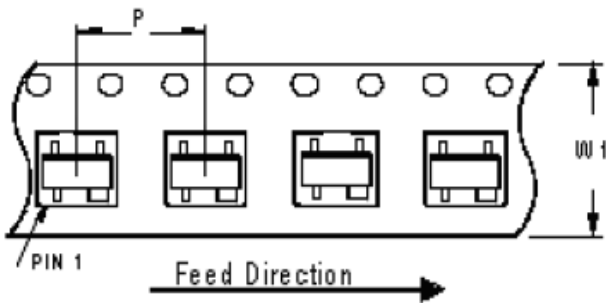

Package Type	Tape Size (W1) (mm)	Pocket Pitch (P) (mm)	Reel Size (A)		Units per Reel	Trailer (mm)	Leader (mm)	Reel Width (W2) Min./Max. (mm)
			(mm)	(in)				
SC-82	8	4	180	7	3,000	160	600	8.4/9.9

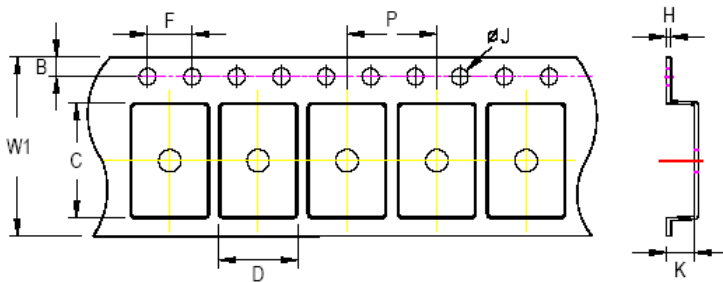

C, D, and K are determined by component size. The clearance between the components and the cavity is as follows:
- For 8mm carrier tape: 0.5mm max.

Tape Size	W1	P		B		F		ØJ		K		H
	Max.	Min.	Max.	Min.	Max.	Min.	Max.	Min.	Max.	Min.	Max.	Max.
8mm	8.3mm	3.9mm	4.1mm	1.65mm	1.85mm	3.9mm	4.1mm	1.5mm	1.6mm	1.1mm	1.3mm	0.6mm

18.1.3 SOT-23-3

SOT/TSOT-23-3:

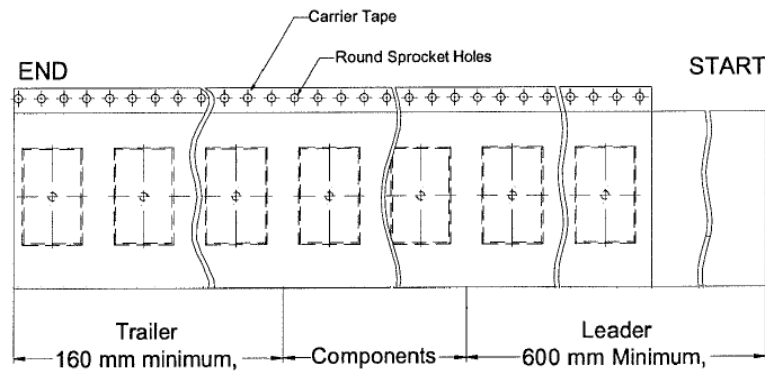
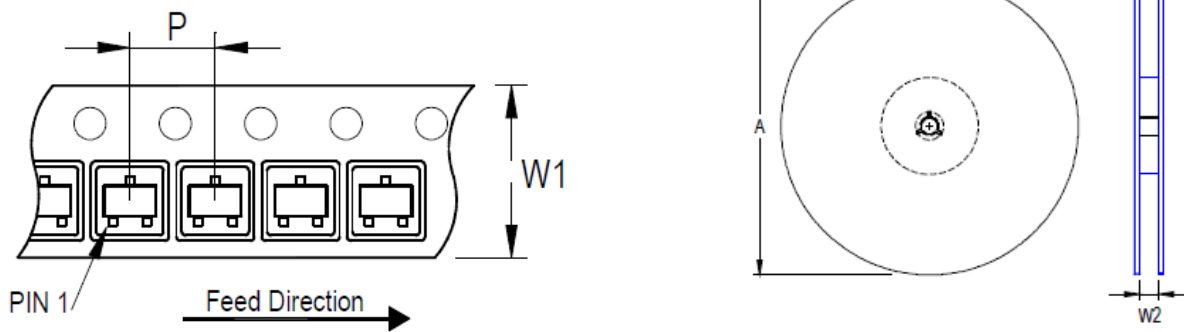

Package Type	Tape Size (W1) (mm)	Pocket Pitch (P) (mm)	Reel Size (A)		Units per Reel	Trailer (mm)	Leader (mm)	Reel Width (W2) Min./Max. (mm)
			(mm)	(in)				
SOT-23-3	8	4	180	7	3,000	160	600	8.4/9.9

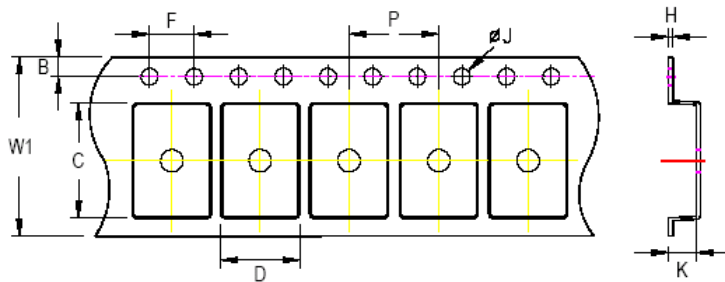

C, D, and K are determined by component size. The clearance between the components and the cavity is as follows:
- For 8mm carrier tape: 0.5mm max.

Tape Size	W1		P		B		F		ØJ		K		H
	Max.	Min.	Max.	Min.	Max.	Min.	Max.	Min.	Max.	Min.	Max.	Max.	
8mm	8.3mm	3.9mm	4.1mm	1.65mm	1.85mm	3.9mm	4.1mm	1.5mm	1.6mm	1.3mm	1.7mm	0.6mm	

18.1.4 SOT-23-5

SOT/TSOT-23-5

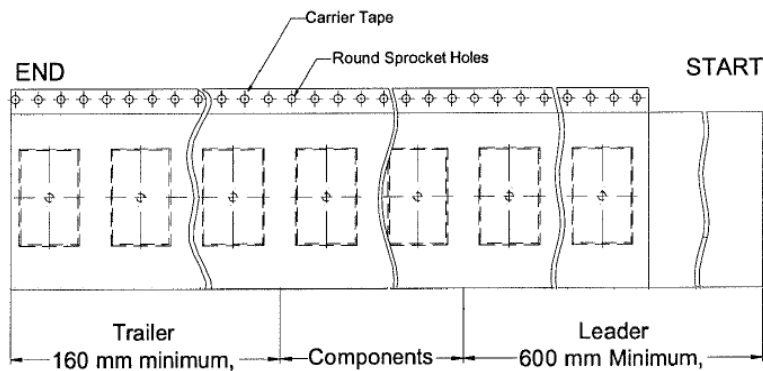
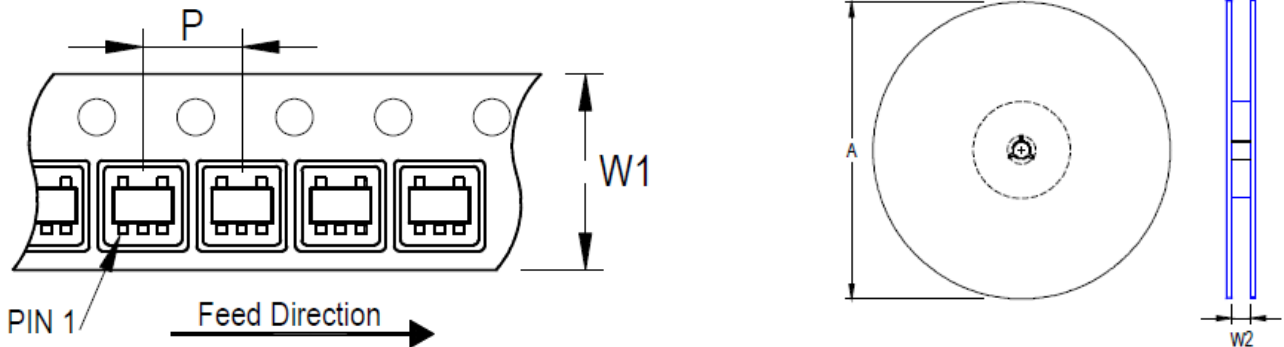

Package Type	Tape Size (W1) (mm)	Pocket Pitch (P) (mm)	Reel Size (A)		Units per Reel	Trailer (mm)	Leader (mm)	Reel Width (W2) Min./Max. (mm)
			(mm)	(in)				
SOT-23-5	8	4	180	7	3,000	160	600	8.4/9.9

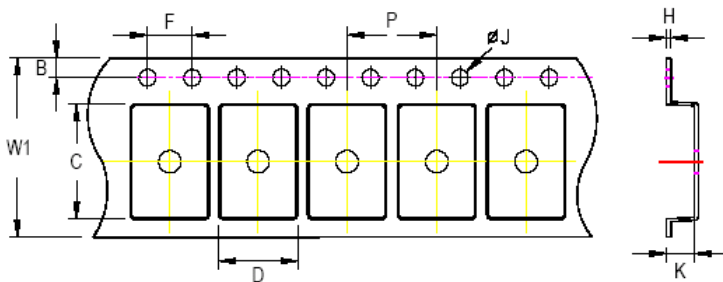

C, D and K are determined by component size.
The clearance between the components and the cavity is as follows:
- For 8mm carrier tape: 0.5mm max.

Tape Size	W1		P		B		F		$\varnothing J$		K		H
	Max.	Min.	Max.	Min.	Max.	Min.	Max.	Min.	Max.	Min.	Max.	Max.	
8mm	8.3mm	3.9mm	4.1mm	1.65mm	1.85mm	3.9mm	4.1mm	1.5mm	1.6mm	1.3mm	1.7mm	0.6mm	

18.1.5 SOT-89

SOT-89:

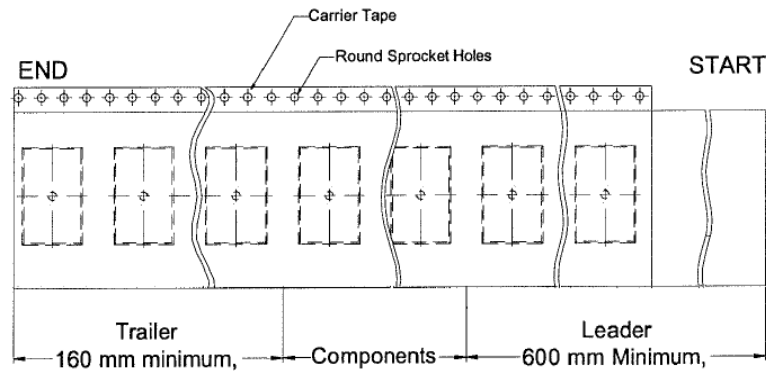
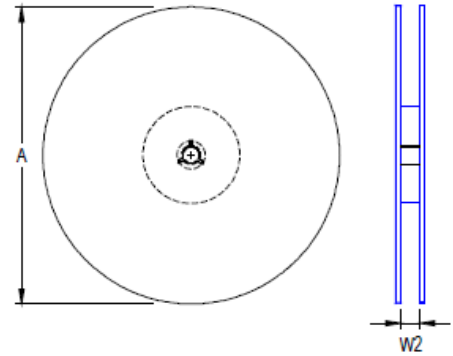
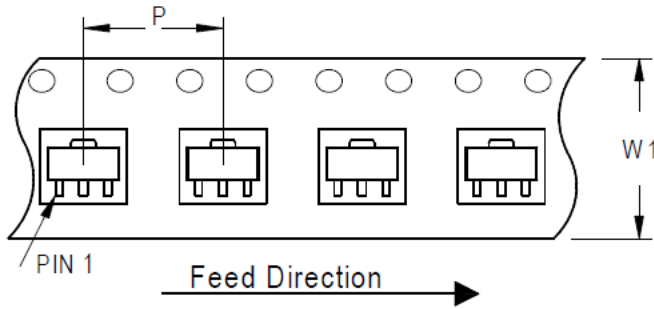

Package Type	Tape Size (W1) (mm)	Pocket Pitch (P) (mm)	Reel Size (A)		Units per Reel	Trailer (mm)	Leader (mm)	Reel Width (W2) Min./Max. (mm)
			(mm)	(in)				
SOT-89	12	8	180	7	1,000	160	600	12.4/14.4

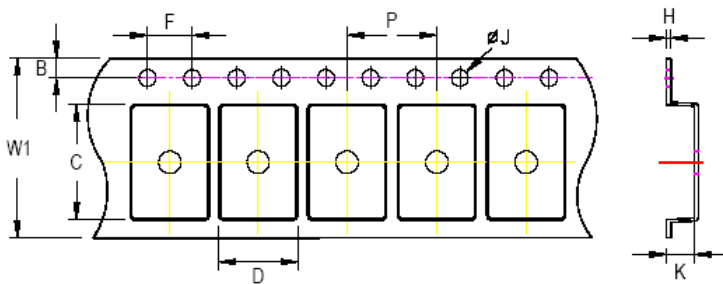







C, D, and K are determined by component size. The clearance between the components and the cavity is as follows:
- For 12mm carrier tape: 0.5mm max.

Tape Size	W1		P		B		F		ØJ		K		H
	Max.	Min.	Max.	Min.	Max.	Min.	Max.	Min.	Max.	Min.	Max.	Max.	
12mm	12.3mm	7.9mm	8.1mm	1.65mm	1.85mm	3.9mm	4.1mm	1.5mm	1.6mm	1.7mm	2.0mm	0.6mm	







18.2 Tape and Reel Packing

18.2.1 SC-70-3

Step	Photo/Description	Step	Photo/Description
1	 Reel 7"	4	 3 reels per inner box Box A
2	 HIC & Desiccant (1 Unit) inside	5	 12 inner boxes per outer box
3	 Caution label is on backside of Al bag	6	 Outer box Carton A







Container Package	Reel		Box			Carton		
	Size	Units	Item	Reels	Units	Item	Boxes	Unit
SC-70-3	7"	3,000	Box A	3	9,000	Carton A	12	108,000
			Box E	1	3,000	For Combined or Partial Reel.		

18.2.2 SC-82

Step	Photo/Description	Step	Photo/Description
1	 <p>Reel 7"</p>	4	 <p>3 reels per inner box Box A</p>
2	 <p>HIC & Desiccant (1 Unit) inside</p>	5	 <p>12 inner boxes per outer box</p>
3	 <p>Caution label is on backside of Al bag</p>	6	 <p>Outer box Carton A</p>







Container Package	Reel		Box			Carton		
	Size	Units	Item	Reels	Units	Item	Boxes	Unit
SC-82	7"	3,000	Box A	3	9,000	Carton A	12	108,000
			Box E	1	3,000	For Combined or Partial Reel.		

18.2.3 SOT-23-3

Step	Photo/Description	Step	Photo/Description
1	 <p>Reel 7"</p>	4	 <p>3 reels per inner box Box A</p>
2	 <p>HIC & Desiccant (1 Unit) inside</p>	5	 <p>12 inner boxes per outer box</p>
3	 <p>Caution label is on backside of Al bag</p>	6	 <p>Outer box Carton A</p>







Container Package	Reel		Box			Carton		
	Size	Units	Item	Reels	Units	Item	Boxes	Unit
SOT-23-3	7"	3,000	Box A	3	9,000	Carton A	12	108,000
			Box E	1	3,000	For Combined or Partial Reel.		

18.2.4 SOT-23-5

Step	Photo/Description	Step	Photo/Description
1	 <p>Reel 7"</p>	4	 <p>3 reels per inner box Box A</p>
2	 <p>HIC & Desiccant (1 Unit) inside</p>	5	 <p>12 inner boxes per outer box</p>
3	 <p>Caution label is on backside of Al bag</p>	6	 <p>Outer box Carton A</p>

Container Package	Reel		Box			Carton		
	Size	Units	Item	Reels	Units	Item	Boxes	Unit
SOT-23-5	7"	3,000	Box A	3	9,000	Carton A	12	108,000
			Box E	1	3,000	For Combined or Partial Reel.		

18.2.5 SOT-89

Step	Photo/Description	Step	Photo/Description
1	 <p>Reel 7"</p>	4	 <p>3 reels per inner box Box A</p>
2	 <p>HIC & Desiccant (1 Unit) inside</p>	5	 <p>12 inner boxes per outer box</p>
3	 <p>Caution label is on backside of Al bag</p>	6	 <p>Outer box Carton A</p>

Container Package	Reel		Box			Carton		
	Size	Units	Item	Reels	Units	Item	Boxes	Unit
SOT-89	7"	1,000	Box A	3	3,000	Carton A	12	36,000
			Box E	1	1,000	For Combined or Partial Reel.		

18.3 Packing Material Anti-ESD Property

Surface Resistance	Aluminum Bag	Reel	Cover tape	Carrier tape	Tube	Protection Band
Ω/cm^2	10^4 to 10^{11}	10^4 to 10^{11}	10^4 to 10^{11}	10^4 to 10^{11}	10^4 to 10^{11}	10^4 to 10^{11}

Richtek Technology Corporation

14F, No. 8, Tai Yuen 1st Street, Chupei City

Hsinchu, Taiwan, R.O.C.

Tel: (8863)5526789

Richtek products are sold by description only. Richtek reserves the right to change the circuitry and/or specifications without notice at any time. Customers should obtain the latest relevant information and data sheets before placing orders and should verify that such information is current and complete. Richtek cannot assume responsibility for use of any circuitry other than circuitry entirely embodied in a Richtek product. Information furnished by Richtek is believed to be accurate and reliable. However, no responsibility is assumed by Richtek or its subsidiaries for its use; nor for any infringements of patents or other rights of third parties which may result from its use. No license is granted by implication or otherwise under any patent or patent rights of Richtek or its subsidiaries.

Copyright © 2024 Richtek Technology Corporation. All rights reserved. **RICHTEK** is a registered trademark of Richtek Technology Corporation.

www.richtek.com

DS9818-12 November 2024

19 Datasheet Revision History

Version	Date	Description	Item
12	2024/11/13	Modify	<i>General Description on page 1</i> -Added Temperature range <i>Applications on page 1</i> -Updated applications <i>Ordering Information on page 1</i> -Added note <i>Electrical Characteristics on page 5</i> -Modified the condition of VOL <i>Footprint Information on page 17 to 21</i> -Added footprint information <i>Packing Information on page 22 to 32</i> -Added packing information