

5Bit VID Reference Generator

General Description

The RT9401A/B are digital to analog converters which generate a reference voltage for Intel VR10.x/AMD K8 5-bit VID code respectively. The parts are proposed to pair with a series of RichTek's general purpose PWM controllers dedicated for the desktop microprocessor core power voltage regulation. The reference voltage is within 1% high accuracy. These parts use a small footprint package of SOT-23-8.

Ordering Information

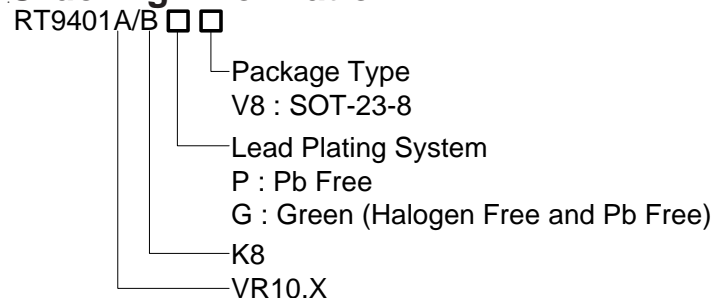

Note :

Richtek products are :

- ▶ RoHS compliant and compatible with the current requirements of IPC/JEDEC J-STD-020.
- ▶ Suitable for use in SnPb or Pb-free soldering processes.

Marking Information

For marking information, contact our sales representative directly or through a Richtek distributor located in your area.

Typical Application Circuit

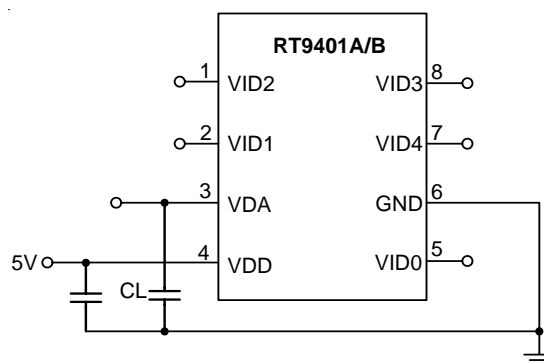

Features

- RT9401A Support 5bit DAC Voltage Conforming to Intel VRD10.x VID Table
- RT9401B Support 5bit DAC Voltage Conforming to AMD K8 VID Table
- 1% High Accuracy of V_{REF}
- Small Footprint Package of SOT-23-8
- RoHS Compliant and 100% Lead (Pb)-Free

Applications

- Desktop/Motherboard Microprocessor Core Power Regulation
- High Accuracy and Programmable Voltage Power Regulation

Pin Configurations

(TOP VIEW)

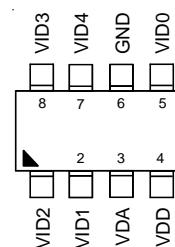

SOT-23-8

Function Block Diagram

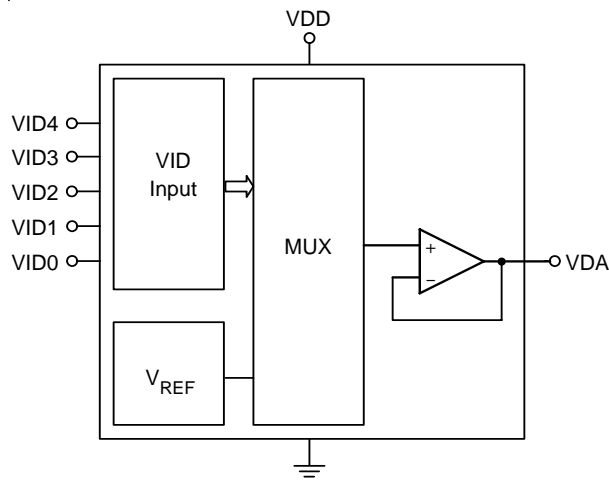

Functional Pin Description

Pin Number	Pin Name	Pin Function
1	VID2	DAC Voltage Identification Inputs.
2	VID1	DAC Voltage Identification Inputs.
3	VDA	Digital - to - Analog Voltage Output.
4	VDD	Power Input Pin.
5	VID0	DAC Voltage Identification Inputs.
6	GND	Ground.
7	VID4	DAC Voltage Identification Inputs.
8	VID3	DAC Voltage Identification Inputs.

Absolute Maximum Ratings (Note 1)

- Supply Input Voltage, V_{DD} ----- 7V
- Power Dissipation, P_D @ $T_A = 25^\circ\text{C}$
 SOT-23-8 ----- 0.4W
- Package Thermal Resistance (Note 2)
 SOT-23-8, θ_{JA} ----- 250°C/W
- Lead Temperature (Soldering, 10 sec.) ----- 260°C
- Storage Temperature Range ----- -65°C to 150°C
- ESD Susceptibility (Note 3)
 HBM (Human Body Mode) ----- 2kV
 MM (Machine Mode) ----- 200V

Recommended Operating Conditions (Note 4)

- Supply Input Voltage, V_{DD} ----- $5V \pm 10\%$
- Junction Temperature Range ----- -40°C to 125°C
- Ambient Temperature Range ----- -40°C to 85°C

Electrical Characteristics

($V_{DD} = 5V$, $T_A = 25^\circ\text{C}$, unless otherwise specified)

Parameter	Symbol	Test Conditions	Min	Typ	Max	Units
V_{DD} Supply Current						
Nominal Supply Current	I_{DD}	VDA open	--	2	5	mA
Reference & DAC						
Output Voltage Program	See Table 1 & Table 2					
DAC Output Voltage Accuracy		$VDA \geq 1V$	-1	--	+1	%
		$VDA < 1V$	-10	--	+10	mV
VID(4:0) Input Low			--	--	0.4	V
VID(4:0) Input High			1.05	--	--	V
VID[4:0] Internal Pull-High Current Source Capability			18	--	--	μA
VID[4:0] Internal Pull-High Voltage		When select AMD CPU	2.2	2.4	2.5	V
		When select Intel CPU	1	1.1	1.2	V
Output Buffer						
DC Gain		Capacitor Load Only	--	70	--	dB
Bandwidth	GBW	$CL=1\text{nF}$	--	1.64	--	MHz
Slew Rate	SR	$CL=0.1\mu\text{F}$	--	9.5	--	$\text{mV}/\mu\text{s}$
Impedance	R_{OUT}		60	--	110	Ω

Note 1. Stresses listed as the above "Absolute Maximum Ratings" may cause permanent damage to the device. These are for stress ratings. Functional operation of the device at these or any other conditions beyond those indicated in the operational sections of the specifications is not implied. Exposure to absolute maximum rating conditions for extended periods may remain possibility to affect device reliability.

Note 2. θ_{JA} is measured in the natural convection at $T_A = 25^\circ\text{C}$ on a low effective thermal conductivity test board of JEDEC 51-3 thermal measurement standard.

Note 3. Devices are ESD sensitive. Handling precaution is recommended.

Note 4. The device is not guaranteed to function outside its operating conditions.

Table 1. Output Voltage Program (VR 10)

Pin Name					Nominal Output Voltage VDA
VID4	VID3	VID2	VID1	VID0	
1	1	1	1	1	OFF
0	1	0	0	1	0.850V
0	1	0	0	0	0.875V
0	0	1	1	1	0.900V
0	0	1	1	0	0.925V
0	0	1	0	1	0.950V
0	0	1	0	0	0.975V
0	0	0	1	1	1.000V
0	0	0	1	0	1.025V
0	0	0	0	1	1.050V
0	0	0	0	0	1.075V
1	1	1	1	0	1.100V
1	1	1	0	1	1.125V
1	1	1	0	0	1.150V
1	1	0	1	1	1.175V
1	1	0	1	0	1.200V
1	1	0	0	1	1.225V
1	1	0	0	0	1.250V
1	0	1	1	1	1.275V
1	0	1	1	0	1.300V
1	0	1	0	1	1.325V
1	0	1	0	0	1.350V
1	0	0	1	1	1.375V
1	0	0	1	0	1.400V
1	0	0	0	1	1.425V
1	0	0	0	0	1.450V
0	1	1	1	1	1.475V
0	1	1	1	0	1.500V
0	1	1	0	1	1.525V
0	1	1	0	0	1.550V
0	1	0	1	1	1.575V
0	1	0	1	0	1.600V

Note: (1) 0 : Connected to GND
 (2) 1 : Open

Table 2. Output Voltage Program (K8)

VID4	VID3	VID2	VID1	VID0	Nominal Output Voltage VDA
0	0	0	0	0	1.550
0	0	0	0	1	1.525
0	0	0	1	0	1.500
0	0	0	1	1	1.475
0	0	1	0	0	1.450
0	0	1	0	1	1.425
0	0	1	1	0	1.400
0	0	1	1	1	1.375
0	1	0	0	0	1.350
0	1	0	0	1	1.325
0	1	0	1	0	1.300
0	1	0	1	1	1.275
0	1	1	0	0	1.250
0	1	1	0	1	1.225
0	1	1	1	0	1.200
0	1	1	1	1	1.175
1	0	0	0	0	1.150
1	0	0	0	1	1.125
1	0	0	1	0	1.100
1	0	0	1	1	1.075
1	0	1	0	0	1.050
1	0	1	0	1	1.025
1	0	1	1	0	1.000
1	0	1	1	1	0.975
1	1	0	0	0	0.950
1	1	0	0	1	0.925
1	1	0	1	0	0.900
1	1	0	1	1	0.875
1	1	1	0	0	0.850
1	1	1	0	1	0.825
1	1	1	1	0	0.800
1	1	1	1	1	Shutdown

Note: (1) 0 : Connected to GND
(2) 1 : Open

Typical Operating Characteristics

V_{VDA} vs. Temperature

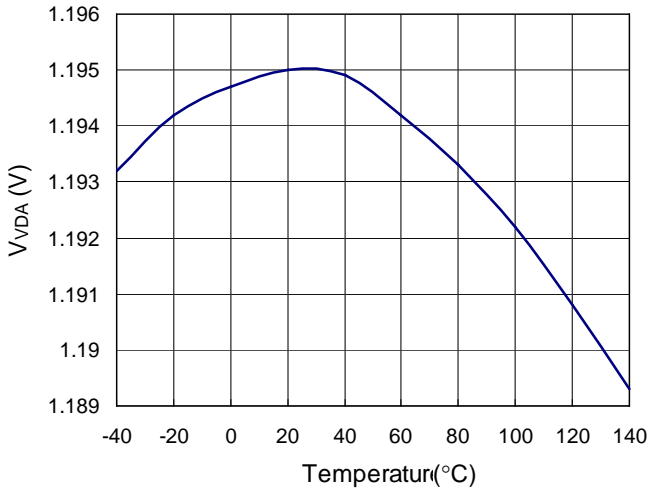

Error Between V_{VID} & V_{VDA}

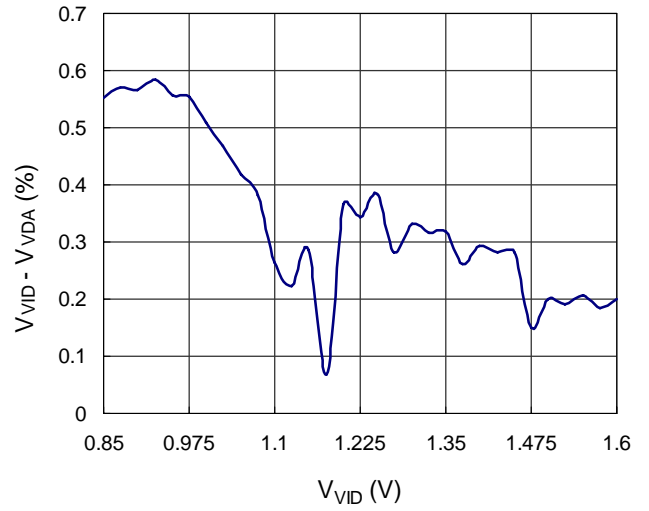

VID on the Fly Falling

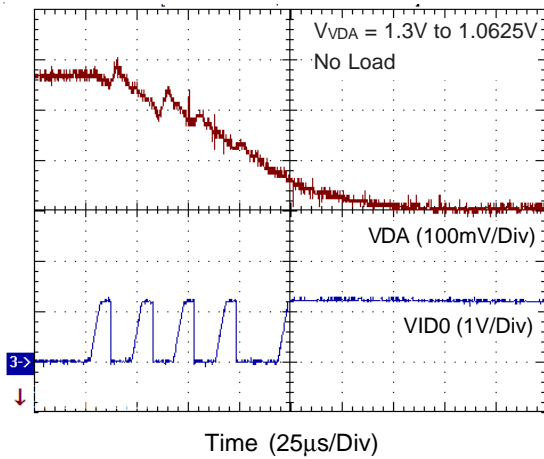

VID on the Fly Rising

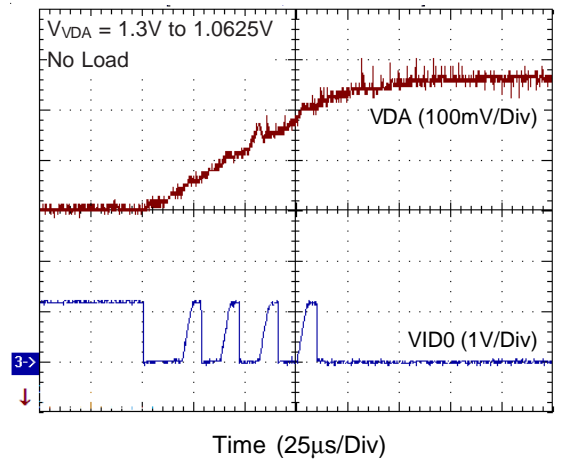

Outline Dimension

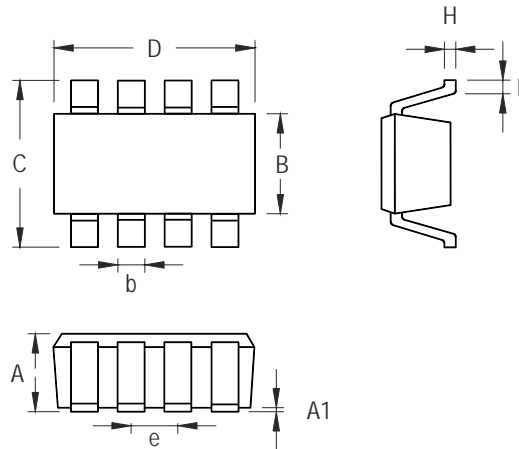

Symbol	Dimensions In Millimeters		Dimensions In Inches	
	Min	Max	Min	Max
A	1.000	1.450	0.039	0.057
A1	0.000	0.150	0.000	0.006
B	1.500	1.700	0.059	0.067
b	0.220	0.500	0.009	0.020
C	2.600	3.000	0.102	0.118
D	2.800	3.000	0.110	0.118
e	0.585	0.715	0.023	0.028
H	0.100	0.220	0.004	0.009
L	0.300	0.600	0.012	0.024

SOT-23-8 Surface Mount Package

Richtek Technology Corporation

Headquarter
 5F, No. 20, Taiyuen Street, Chupei City
 Hsinchu, Taiwan, R.O.C.
 Tel: (8863)5526789 Fax: (8863)5526611

Richtek Technology Corporation

Taipei Office (Marketing)
 5F, No. 95, Minchiuan Road, Hsintien City
 Taipei County, Taiwan, R.O.C.
 Tel: (8862)86672399 Fax: (8862)86672377
 Email: marketing@richtek.com

Information that is provided by Richtek Technology Corporation is believed to be accurate and reliable. Richtek reserves the right to make any change in circuit design, specification or other related things if necessary without notice at any time. No third party intellectual property infringement of the applications should be guaranteed by users when integrating Richtek products into any application. No legal responsibility for any said applications is assumed by Richtek.