

# Asynchronous Boost Converter for Driving Up to 10 WLEDs

## 1 General Description

The RT4533/A is a highly integrated LED driver IC capable of driving up to 10 WLEDs in series. It composes a current mode Boost converter integrated with a 36.5V/1.2A power switch.

The RT4533/A supports a wide input voltage range from 2.5V to 5.5V and operates at a fixed frequency of 1.1MHz. The LED current is set through an external resistor, and the feedback voltage is regulated to either 200mV or 300mV. For brightness dimming, the RT4533/A supports PWM dimming, which determines the feedback reference voltage.

The recommended junction temperature range is -40°C to 125°C, and the ambient temperature range is -40°C to 85°C.

## 2 Applications

- Cellular Phones
- Digital Cameras
- Probable Instruments

## 3 Marking Information

RT4533GJ6

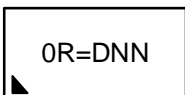

0R=: Product Code  
DNN: Date Code

RT4533AGJ6

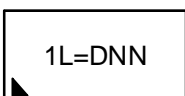

1L=: Product Code  
DNN: Date Code

## 4 Features

- Input Voltage Range from 2.5V to 5.5V
- 36.5V Open LED Protection for Up to 10 WLEDs
- PWM Dimming for Adjustable Brightness Control
- Reference Voltage of 200mV / 300mV with ±2% Accuracy
- Switching Frequency at 1.1MHz
- Built-In Feature for Soft-Start
- Over-Temperature Protection
- Internal Compensation
- Current Limit Feature

## 5 Ordering Information

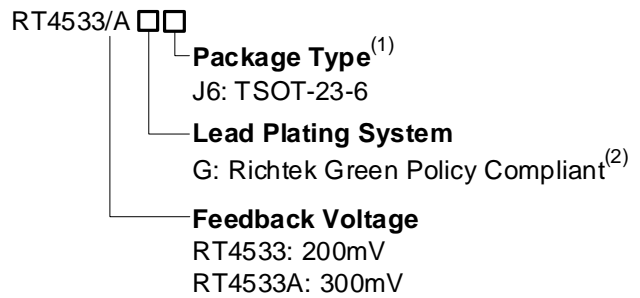

### Note 1.

- Marked with <sup>(1)</sup> indicated: Compatible with the current requirements of IPC/JEDEC J-STD-020.
- Marked with <sup>(2)</sup> indicated: Richtek products are Richtek Green Policy compliant.

## 6 Simplified Application Circuit

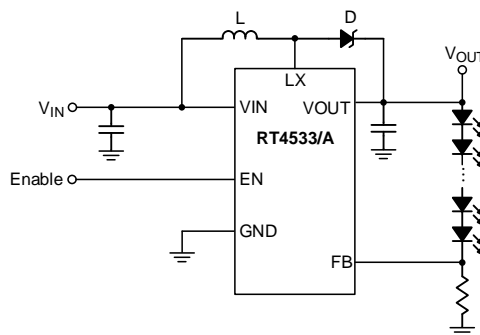

## Table of Contents

<b>1</b>	<b>General Description</b> .....	<b>1</b>	<b>17</b>	<b>Application Information</b> .....	<b>9</b>
<b>2</b>	<b>Applications</b> .....	<b>1</b>	17.1	Soft-Start.....	9
<b>3</b>	<b>Marking Information</b> .....	<b>1</b>	17.2	LED Current.....	9
<b>4</b>	<b>Features</b> .....	<b>1</b>	17.3	Current Limit.....	9
<b>5</b>	<b>Ordering Information</b> .....	<b>1</b>	17.4	Shutdown Delay .....	9
<b>6</b>	<b>Simplified Application Circuit</b> .....	<b>1</b>	17.5	PWM Dimming .....	9
<b>7</b>	<b>Pin Configuration</b> .....	<b>3</b>	17.6	Inductor Selection .....	9
<b>8</b>	<b>Functional Pin Description</b> .....	<b>3</b>	17.7	Capacitor Selection .....	10
<b>9</b>	<b>Functional Block Diagram</b> .....	<b>3</b>	17.8	Thermal Considerations .....	10
<b>10</b>	<b>Absolute Maximum Ratings</b> .....	<b>4</b>	17.9	Layout Considerations .....	11
<b>11</b>	<b>Recommended Operating Conditions</b> .....	<b>4</b>	<b>18</b>	<b>Outline Dimension</b> .....	<b>13</b>
<b>12</b>	<b>Electrical Characteristics</b> .....	<b>5</b>	<b>19</b>	<b>Footprint Information</b> .....	<b>14</b>
<b>13</b>	<b>Typical Application Circuit</b> .....	<b>6</b>	<b>20</b>	<b>Packing Information</b> .....	<b>15</b>
<b>14</b>	<b>Timing Diagram</b> .....	<b>6</b>	20.1	Tape and Reel Data .....	15
<b>15</b>	<b>Typical Operating Characteristics</b> .....	<b>7</b>	20.2	Tape and Reel Packing .....	15
<b>16</b>	<b>Operation</b> .....	<b>8</b>	20.3	Packing Material Anti-ESD Property.....	17
16.1	UVLO.....	8	<b>21</b>	<b>Datasheet Revision History</b> .....	<b>18</b>
16.2	Soft-Start .....	8			
16.3	EN Dimming .....	8			
16.4	OCP.....	8			
16.5	OVP.....	8			
16.6	OTP .....	8			

### 7 Pin Configuration

(TOP VIEW)

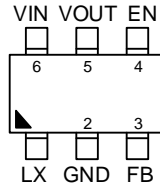

TSOT-23-6

### 8 Functional Pin Description

Pin No.	Pin Name	Pin Function
1	LX	Switch node.
2	GND	Ground.
3	FB	Feedback Voltage Input. Connect a resistor to GND to set the current.
4	EN	Enable control input (PWM dimming).
5	VOUT	Output voltage pin.
6	VIN	Supply voltage input.

### 9 Functional Block Diagram

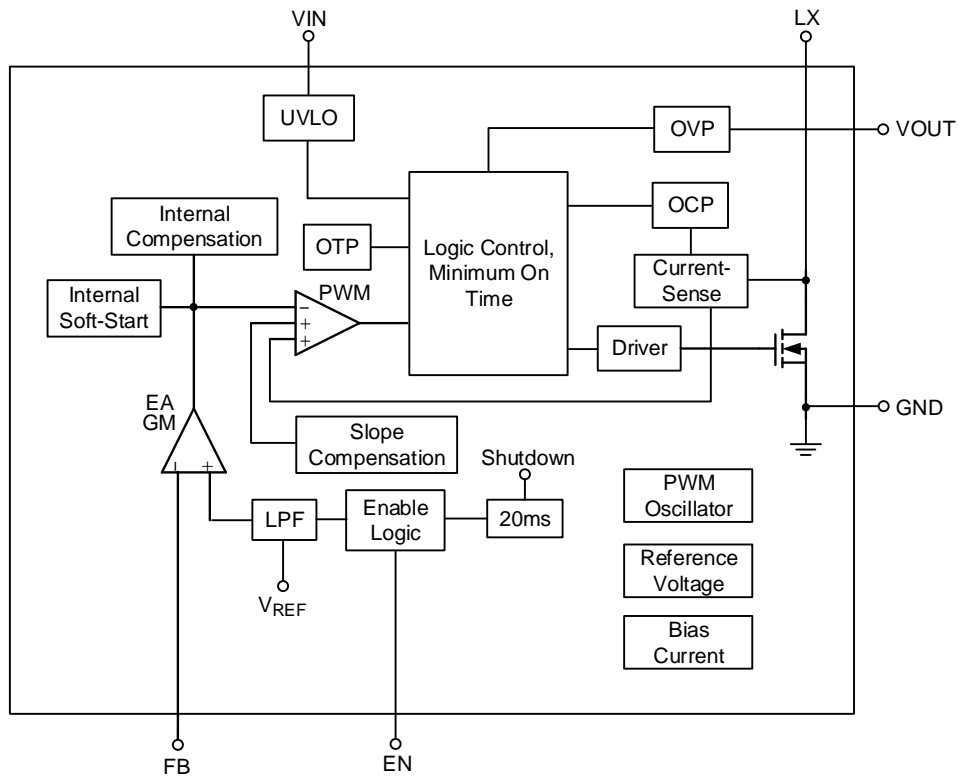

## 10 Absolute Maximum Ratings

(Note 2)

- VIN ----- -0.3V to 6.5V
- EN, FB to GND----- -0.3V to (VIN + 3V)
- LX to GND----- -0.3V to 38V
- VOUT to GND ----- -0.3V to 40V
- Power Dissipation, PD @ TA = 25°C  
 TSOT-23-6 ----- 0.5W
- Package Thermal Resistance (Note 3)  
 TSOT-23-6,  $\theta_{JA}$  ----- 197.4°C/W
- Lead Temperature (Soldering, 10 sec.) ----- 260°C
- Junction Temperature ----- -40°C to 150°C
- Storage Temperature Range ----- -65°C to 150°C
- ESD Susceptibility (Note 4)  
 HBM (Human Body Model)----- 2kV

**Note 2.** Stresses beyond those listed under “Absolute Maximum Ratings” may cause permanent damage to the device. These are stress ratings only, and functional operation of the device at these or any other conditions beyond those indicated in the operational sections of the specifications is not implied. Exposure to absolute maximum rating conditions may affect device reliability.

**Note 3.**  $\theta_{JA}$  is measured under natural convection (still air) at TA = 25°C with the component mounted on a high effective-thermal-conductivity four-layer test board on a JEDEC 51-7 thermal measurement standard.

**Note 4.** Devices are ESD sensitive. Handling precautions are recommended.

## 11 Recommended Operating Conditions

(Note 5)

- Supply Input Voltage, VIN----- 2.5V to 5.5V
- Ambient Temperature Range----- -40°C to 85°C
- Junction Temperature Range----- -40°C to 125°C

**Note 5.** The device is not guaranteed to function outside its operating conditions.

**12 Electrical Characteristics**

( $V_{IN} = 3.6V$ ,  $C_{IN} = 4.7\mu F$ ,  $C_{OUT} = 1\mu F$ ,  $L = 22\mu H$ ,  $f_{SW} = 1.1MHz$ ,  $T_A = 25^\circ C$ , unless otherwise specified.)

Parameter	Symbol	Test Conditions	Min	Typ	Max	Unit
<b>Power Supply</b>						
IC Operating Current (Switching)	I <sub>Q_SW</sub>	V <sub>FB</sub> = 0V	0.25	0.8	1.5	mA
IC Quiescent Current (Non-Switching)	I <sub>Q_NSW</sub>	V <sub>FB</sub> = 0.4V	0.25	0.35	0.5	mA
V <sub>IN</sub> Pin Shutdown Current	I <sub>SHDN</sub>	EN = GND	--	0.3	1	μA
Undervoltage Lockout Threshold,	V <sub>UVLO_R</sub>	V <sub>IN</sub> rising edge	2.25	2.37	2.5	V
Undervoltage Lockout Hysteresis	V <sub>UVLO_HSY</sub>	V <sub>IN</sub> falling edge	--	80	--	mV
<b>Enable and Reference Control</b>						
EN Input Voltage Logic-High	V <sub>EN_R</sub>		1.4	--	--	V
EN Input Voltage Logic-Low	V <sub>EN_F</sub>		--	--	0.4	V
EN Pull Low Resistance	R <sub>PD</sub>		--	300	--	kΩ
EN Minimum Shutdown Pulse Width	t <sub>OFF</sub>		20	--	--	ms
EN Minimum Logic-High Pulse Width	t <sub>HIGH_MIN</sub>		0.5	--	--	μs
EN Minimum Logic-Low Pulse Width	t <sub>LOW</sub>		1	--	10000	μs
Internal Comp Resistance	R <sub>COMP</sub>		--	7	--	MΩ
PWM Minimum Duty	D <sub>MIN</sub>		--	3	--	%
PWM Frequency	f <sub>PWM</sub>		5	--	100	kHz
<b>Voltage And Current Control</b>						
Feedback Regulation Voltage	RT4533	V <sub>FB</sub>	196	200	204	mV
	RT4533A		294	300	306	
Feedback Pin Bias Current	I <sub>FB</sub>		--	--	0.1	μA
Oscillator Frequency	f <sub>SW</sub>		0.99	1.1	1.21	MHz
Maximum Duty Cycle	D <sub>MAX</sub>		--	93	--	%
<b>Power Switch</b>						
N-MOSFET On-Resistance	R <sub>D<sub>S</sub>_ON</sub>	V <sub>IN</sub> = 3.6V	--	0.4	0.7	Ω
<b>OC and OLP</b>						
Peak N-MOSFET Current Limit	I <sub>LIM</sub>		1.0	1.2	1.4	A
Open LED Protection Threshold	V <sub>OVP</sub>		35	36.5	38	V
<b>Thermal Shutdown</b>						
Thermal Shutdown Threshold	T <sub>OTP</sub>		--	160	--	°C
Thermal Shutdown Hysteresis	T <sub>OTP_HYS</sub>		--	15	--	°C

13 Typical Application Circuit

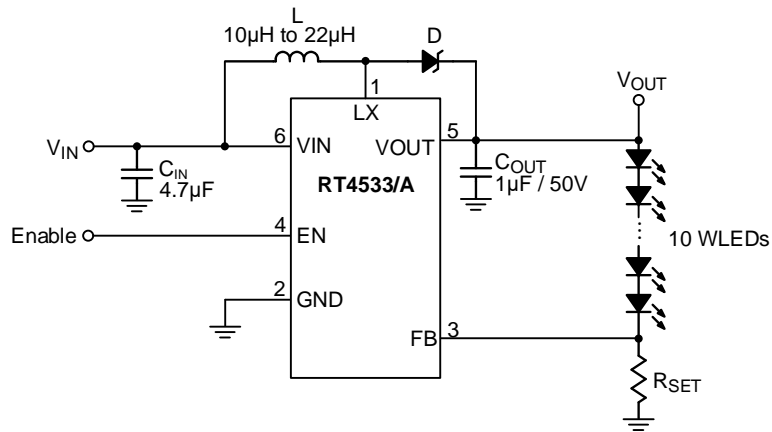

14 Timing Diagram

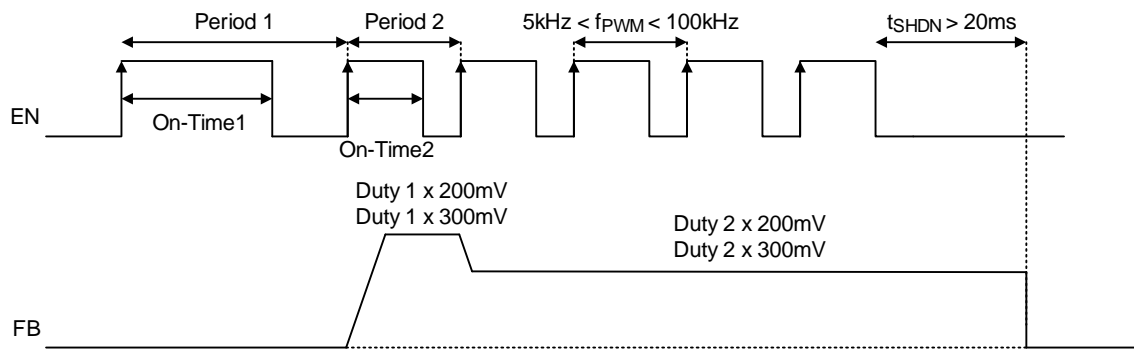

Duty 1: On-Time 1 / Period 1  
 Duty 2: On-Time 2 / Period 2

**15 Typical Operating Characteristics**

**Efficiency vs. Output Current**

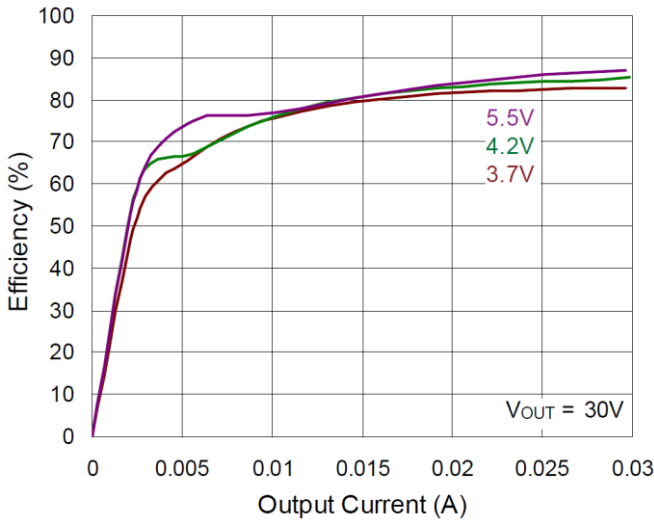

**Efficiency vs. Input Voltage**

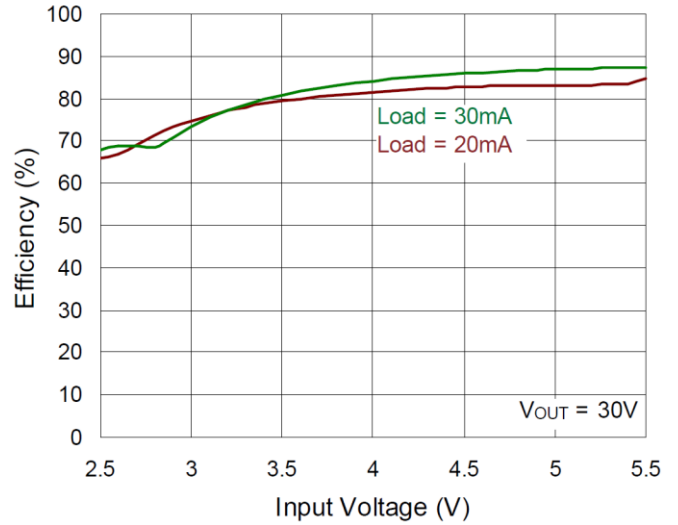

**Operating Quiescent Current vs. Input Voltage**

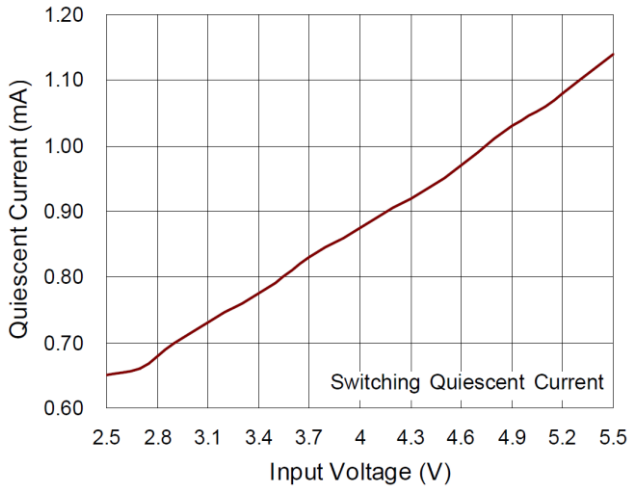

**I<sub>LED</sub> vs. Duty**

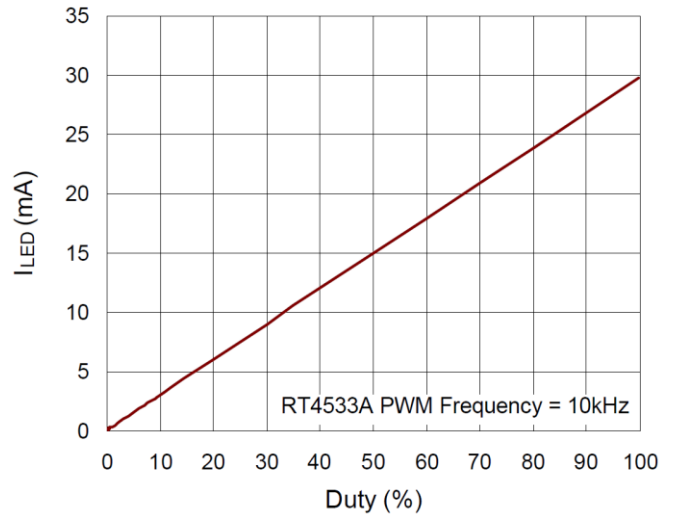

**Oscillator Frequency vs. Temperature**

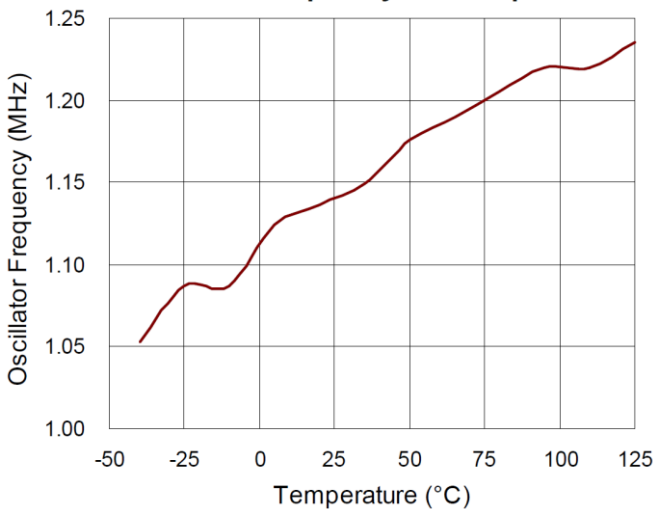

**Reference Voltage vs. Output Current**

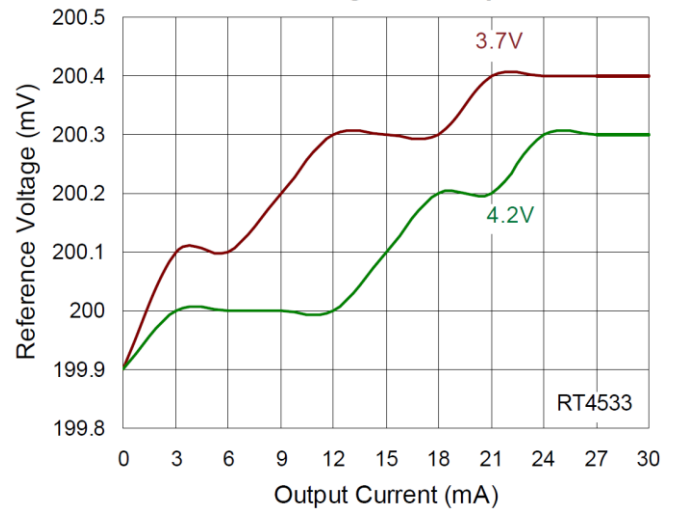

## 16 Operation

The RT4533/A is a boost LED driver that operates with a constant frequency and constant current mode. During normal operation, the N-MOSFET is turned on by the PWM Control circuit, which is set by the oscillator, and is turned off when the current comparator resets the PWM Control circuit. When the N-MOSFET is turned off, the inductor current flows through the external diode instead.

### 16.1 UVLO

The driver turns off when the input voltage lower than the UVLO threshold (2.37V typical), with an 80mV hysteresis control for the UVLO.

### 16.2 Soft-Start

When the device is enabled, the compensation gradually ramps up to the target voltage within a specific time frame. This ensures a slow rise in the output voltage to minimize the input inrush current.

### 16.3 EN Dimming

The EN pin serves as the control input for both PWM dimming and digital dimming modes. If the EN voltage remains logic low for more than a specified duration, the driver will shut down after a delay.

### 16.4 OCP

The driver features a cycle-by-cycle current limit function to control the current in the power switch. The boost switch turns off when the inductor current reaches the threshold, and it remains off until the next switching cycle begins. The OCP function protects the RT4533/A and external components under overload conditions.

### 16.5 OVP

The Overvoltage Protection is detected through a resistor divider circuit connected to VOUT.

If VOUT exceeds the OVP voltage, the LX pin stops switching, and the MOSFET turns off. VOUT is then discharged through an external resistor. OVP is reset when EN transitions from low to high again.

### 16.6 OTP

If the die temperature exceeds 160°C, the chip enters protection mode, turning off the MOSFET to prevent abnormal operation. The device automatically exits shutdown mode when the junction temperature decreases by 15°C.



## 17 Application Information

[\(Note 6\)](#)

### 17.1 Soft-Start

The RT4533/A includes a soft-start function designed to prevent high inrush current at start-up. This function is implemented by limiting the output voltage of the error amplifier, with a voltage source that ramps up from zero to approximately VIN.

### 17.2 LED Current

The loop control of the Boost converter maintains VFB at a level equal to the reference voltage, VREF. Thus, with RSET connected between the FB pin and GND, the LED current is determined by the current flowing through RSET, which is equal to VFB / RSET.

### 17.3 Current Limit

The current sensing circuit detects the current flowing through the inductor during the charging phase. If the value exceeds the current limit, the N-MOSFET is turned off, forcing the inductor to transition from the charging phase. Therefore, the inductor current is prevented from surpassing the current limit.

### 17.4 Shutdown Delay

If the EN voltage stays at a logic low for 20ms during PWM dimming, the system enters shutdown mode.

### 17.5 PWM Dimming

Constantly holding the EN pin high typically regulates the FB voltage to 200mV or 300mV. The RT4533/A allows for the use of a PWM signal from the EN pin to reduce the regulation voltage, facilitating LED brightness dimming. The FB voltage is directly proportional to the duty cycle of the PWM signal, as described by the equation:

$$V_{FB} = \text{Duty} \times V_{REF}$$

Where

Duty = The duty cycle of the PWM signal

VREF = Internal reference voltage (200mV or 300mV typical)

The RT4533/A automatically determines the internal reference voltage based on the duty cycle of the PWM signal to ensure optimal performance. Therefore, even though a PWM signal is utilized for brightness dimming, only the LED DC current is modulated, which is often referred to as analog dimming. This approach effectively eliminates the audible noise typically associated with pulsing the LED current to match the PWM signal's frequency and duty cycle. For optimal performance and to ensure efficient analog dimming, a PWM dimming frequency within the range of 5kHz to 100kHz is recommended. To minimize potential audio noise, it is recommended to set the PWM dimming frequency above 20kHz.

### 17.6 Inductor Selection

For configurations supporting up to 10 LEDs or for high-brightness LEDs, it is recommended to use an inductor with a value ranging from 10µH to 22µH. For portable devices, smaller size and better efficiency are the primary considerations. The inductor should demonstrate minimal core loss at 1MHz and a low DCR for enhanced efficiency. It is important to consider the inductor saturation current rating to accommodate the inductor peak current. [Table 1](#) provides a list of recommended inductors for the RT4533/A.

Table 1.

Part Number	L ( $\mu\text{H}$ )	DCR MAX ( $\text{m}\Omega$ )	Saturation Current (A)	Size (L x W x H mm)	Vendor
NR4018T100M	10	216	1.2	4x4 x1.8	TAIYO
NR4018T220M	22	432	0.8	4x4x1.8	TAIYO

### 17.7 Capacitor Selection

To achieve a low ripple voltage, the use of ceramic capacitors with low ESR is recommended. X5R and X7R capacitor types are preferred due to their wide voltage range and stable temperature characteristics. For applications where the RT4533/A is utilized to drive up to 10 LEDs in series, a 4.7 $\mu\text{F}$  input capacitor and a 1 $\mu\text{F}$ , 50V output capacitor are recommended.

### 17.8 Thermal Considerations

To prevent permanent damage to the device, ensure that the junction temperature never exceeds the absolute maximum junction temperature  $T_{J(\text{MAX})}$  as specified in the Absolute Maximum Ratings. The maximum allowable power dissipation is influenced by the thermal resistance of the IC package, the PCB layout, the surrounding airflow rate, and the temperature difference between the junction and ambient temperatures. The maximum power dissipation can be calculated using the following formula:

$$P_{D(\text{MAX})} = (T_{J(\text{MAX})} - T_A) / \theta_{JA}$$

where  $T_{J(\text{MAX})}$  is the maximum junction temperature,  $T_A$  is the ambient temperature, and  $\theta_{JA}$  is the junction-to-ambient thermal resistance.

For continuous operation, the maximum operating junction temperature specified under Recommended Operating Conditions is 125°C. The junction-to-ambient thermal resistance,  $\theta_{JA}$ , is significantly depending on the package type. For a TSOT-23-6 package, the thermal resistance,  $\theta_{JA}$ , is 197.4°C/W on a standard JEDEC 51-7 high effective-thermal-conductivity four-layer test board. The maximum power dissipation at  $T_A = 25^\circ\text{C}$  can be calculated as below:

$$P_{D(\text{MAX})} = (125^\circ\text{C} - 25^\circ\text{C}) / (197.4^\circ\text{C}/\text{W}) = 0.5\text{W for a TSOT-23-6 package.}$$

The maximum power dissipation depends on the operating ambient temperature for the fixed  $T_{J(\text{MAX})}$  and the thermal resistance,  $\theta_{JA}$ . The derating curve in Figure 1 allows the designer to observe the impact of increasing ambient temperature on the maximum power dissipation.

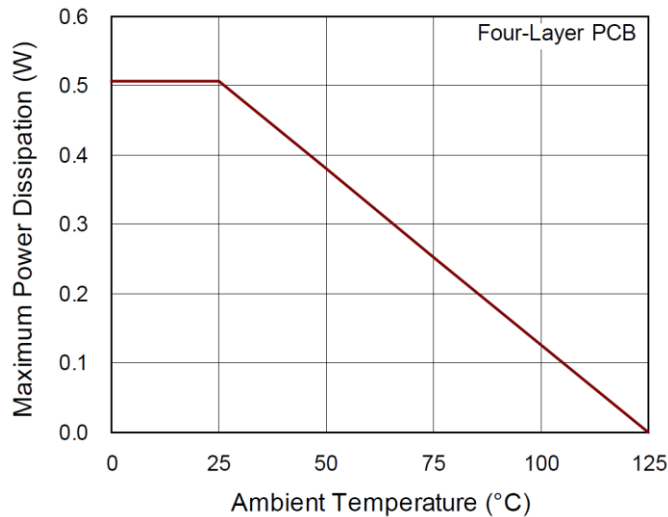

Figure 1. Derating Curve of Maximum Power Dissipation

### 17.9 Layout Considerations

For optimal performance of the RT4533/A, adhere to the following guidelines:

- Place input and output capacitors close to the IC and connect to the ground plane to reduce noise coupling.
- Connect both the GND and the Exposed Pad to a robust ground plane to enhance heat dissipation and provide noise protection.
- Keep the main current traces as short and wide as possible.
- The LX node of the DC-DC converter experiences high-frequency voltage swing and should be kept in a small area to prevent electromagnetic interference.
- Place the feedback components as close as possible to the IC and keep them away from the noisy devices.

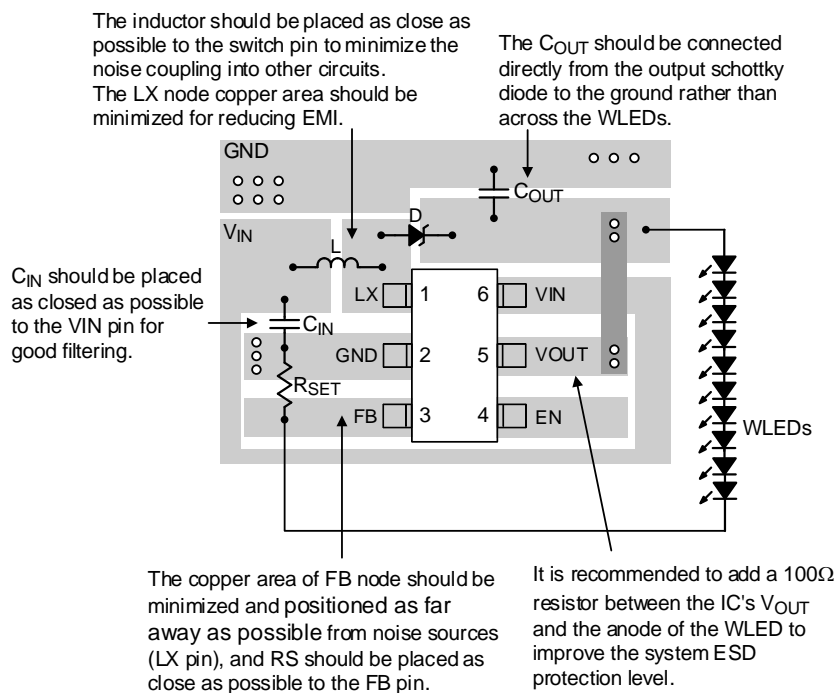
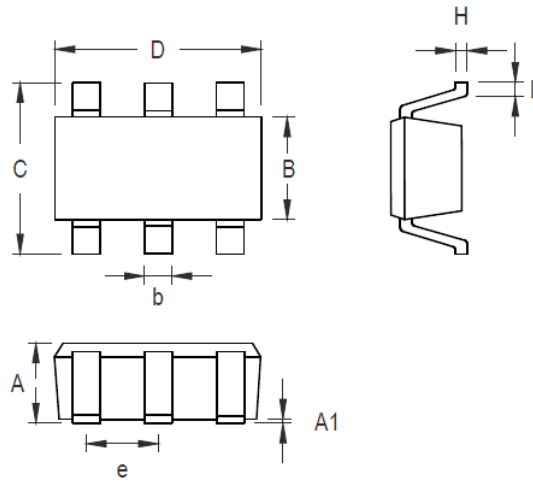

Figure 2. PCB Layout Guide

**Note 6.** The information provided in this section is for reference only. The customer is solely responsible for designing, validating, and testing any applications incorporating Richtek's product(s). The customer is also responsible for applicable standards and any safety, security, or other requirements.

**18 Outline Dimension**



Symbol	Dimensions In Millimeters		Dimensions In Inches	
	Min	Max	Min	Max
A	0.700	1.000	0.028	0.039
A1	0.000	0.100	0.000	0.004
B	1.397	1.803	0.055	0.071
b	0.300	0.559	0.012	0.022
C	2.591	3.000	0.102	0.118
D	2.692	3.099	0.106	0.122
e	0.838	1.041	0.033	0.041
H	0.080	0.254	0.003	0.010
L	0.300	0.610	0.012	0.024

**TSOT-23-6 Surface Mount Package**

19 Footprint Information

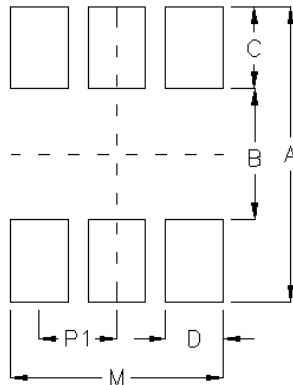

Package	Number of Pin	Footprint Dimension (mm)						Tolerance
		P1	A	B	C	D	M	
TSOT-26/TSOT-26(FC)/SOT-26/SOT-26(COL)	6	0.95	3.60	1.60	1.00	0.70	2.60	±0.10

**20 Packing Information**

**20.1 Tape and Reel Data**

**SOT/TSOT-23-6/8:**

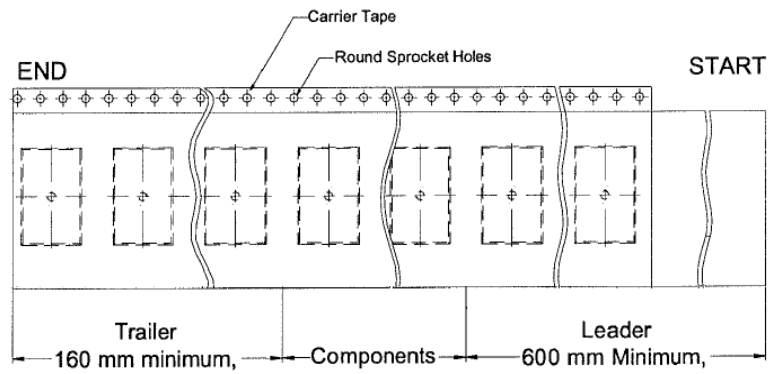
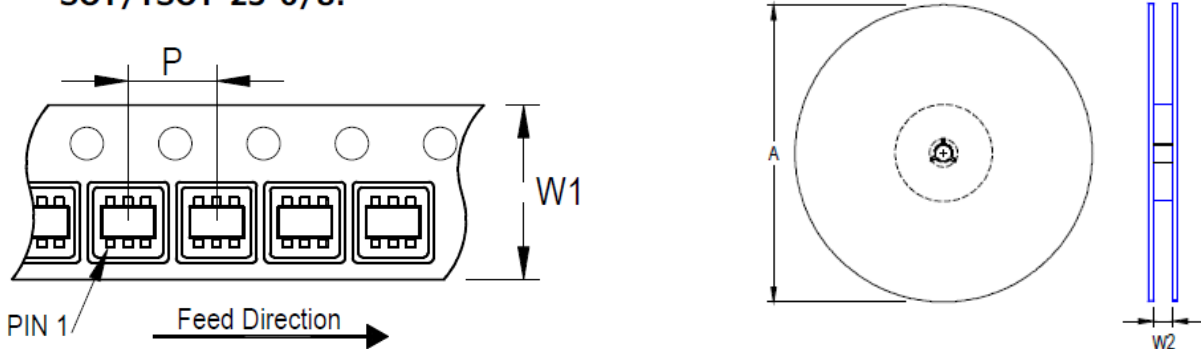



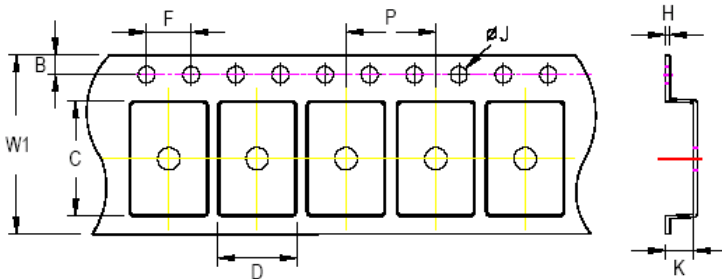



Package Type	Tape Size (W1) (mm)	Pocket Pitch (P) (mm)	Reel Size (A)		Units per Reel	Trailer (mm)	Leader (mm)	Reel Width (W2) Min./Max. (mm)
			(mm)	(in)				
TSOT-23-6	8	4	180	7	3,000	160	600	8.4/9.9



**C, D, and K are determined by component size.**  
**The clearance between the components and the cavity is as follows:**  
**- For 8mm carrier tape: 0.5mm max.**

Tape Size	W1	P		B		F		ØJ		K		H
	Max	Min	Max	Min	Max	Min	Max	Min	Max	Min	Max	Max
8mm	8.3mm	3.9mm	4.1mm	1.65mm	1.85mm	3.9mm	4.1mm	1.5mm	1.6mm	1mm	1.2mm	0.6mm

## 20.2 Tape and Reel Packing

Step	Photo/Description	Step	Photo/Description
1	 <p>Reel 7"</p>	4	 <p>3 reels per inner box <b>Box A</b></p>
2	 <p>HIC &amp; Desiccant (1 Unit) inside</p>	5	 <p>12 inner boxes per outer box</p>
3	 <p>Caution label is on backside of Al bag</p>	6	 <p>Outer box <b>Carton A</b></p>

Package	Reel		Box			Carton		
	Size	Units	Item	Reels	Units	Item	Boxes	Unit
TSOT-23-6	7"	3,000	Box A	3	9,000	Carton A	12	108,000
			Box E	1	3,000	For Combined or Partial Reel.		



**20.3 Packing Material Anti-ESD Property**

Surface Resistance	Aluminum Bag	Reel	Cover tape	Carrier tape	Tube	Protection Band
$\Omega/\text{cm}^2$	$10^4$ to $10^{11}$	$10^4$ to $10^{11}$	$10^4$ to $10^{11}$	$10^4$ to $10^{11}$	$10^4$ to $10^{11}$	$10^4$ to $10^{11}$

**Richtek Technology Corporation**

14F, No. 8, Tai Yuen 1<sup>st</sup> Street, Chupei City

Hsinchu, Taiwan, R.O.C.

Tel: (8863)5526789

**RICHTEK**

Richtek products are sold by description only. Richtek reserves the right to change the circuitry and/or specifications without notice at any time. Customers should obtain the latest relevant information and data sheets before placing orders and should verify that such information is current and complete. Richtek cannot assume responsibility for use of any circuitry other than circuitry entirely embodied in a Richtek product. Information furnished by Richtek is believed to be accurate and reliable. However, no responsibility is assumed by Richtek or its subsidiaries for its use; nor for any infringements of patents or other rights of third parties which may result from its use. No license is granted by implication or otherwise under any patent or patent rights of Richtek or its subsidiaries.

Copyright © 2024 Richtek Technology Corporation. All rights reserved. **RICHTEK** is a registered trademark of Richtek Technology Corporation.

**21 Datasheet Revision History**

Version	Date	Description	Item
03	2024/12/16	Modify	General Description on P1 Ordering Information on P1 Electrical Characteristics on P6 Footprint Information on P14 Packing Information on P15, 16, 17