

# High-Efficiency POL Power Solution for Next-Generation AI Servers: RTQ2811A

Chang Lin, Jack Liu, Sophia Tong | AN094

As AI, cloud computing, and big data continue to drive higher computing density, server power designs are facing increasingly stringent requirements for high efficiency, low noise, fast transient response, and high reliability. Next-generation server SSDs and Point-of-Load (POL) applications not only require high-current, low-voltage power delivery, but also demand high power density, a compact PCB footprint, and intelligent power management capability.

Richtek's [RTQ2811A](#) is specifically designed for next-generation server platforms. Featuring a high-efficiency synchronous buck converter architecture with integrated I<sup>2</sup>C digital monitoring and flexible multiphase configuration, the [RTQ2811A](#) improves power conversion efficiency, minimizes output ripple, and delivers fast transient response for high-performance server and storage applications. This enables a highly stable and efficient POL power solution for modern data center systems.

## Table of Contents

<b>1</b>	<b>Server SSD and Point of Load Power Supply Design Challenges</b> .....	<b>3</b>
1.1	Smart Power Trends: Higher Efficiency, Smart Monitoring, and Stability Requirements.....	3
1.2	Size Constraints in Highly Integrated Designs.....	3
<b>2</b>	<b>Control Topology Selection Based on System Requirements</b> .....	<b>4</b>
2.1	Dual-Phase Control.....	4
2.1.1	Reduced Output Capacitor Requirements.....	4
2.1.2	Fast Transient Response.....	4
2.1.3	Balanced Current Sharing.....	4
2.1.4	High Flexibility.....	4
2.2	Two-Channel Control.....	5
2.2.1	Simple Structure and Easy Implementation.....	5
2.2.2	BOM Cost Advantage.....	5
2.2.3	Flexible Power Sequencing.....	5
2.3	Parallel Control.....	6
2.3.1	Fewer Inductors Required.....	6
2.3.2	Simpler Control Method.....	6
2.3.3	Lower Architecture Complexity.....	6
<b>3</b>	<b>Advantages of the Design Scheme</b> .....	<b>8</b>
3.1	High-Precision, Low-Noise Power Control Topology.....	8
3.1.1	Excellent Temperature Compensation.....	8
3.1.2	Accurate Output Voltage Regulation.....	9
3.1.3	Fast Load Transient Response.....	10
3.2	High Power Efficiency and Thermal Management.....	10
3.2.1	High-Temperature Warning and Reporting.....	11
3.2.2	Over-Temperature Protection.....	11
3.3	ADC Detection and Monitoring.....	11
<b>4</b>	<b>Conclusion</b> .....	<b>12</b>

## 1 Server SSD and Point of Load Power Supply Design Challenges

As server SSDs and Point-of-Load (POL) applications continue to advance toward higher performance and greater power density, power supply design is facing increasingly demanding challenges: Rapid load current transients generated by high-performance processors, controllers, and memory devices require fast transient response, accurate voltage regulation, and robust system stability. At the same time, higher system integration and tighter PCB height constraints make thermal management and power delivery performance more difficult to balance.

### 1.1 Smart Power Trends: Higher Efficiency, Smart Monitoring, and Stability Requirements

Next-generation server power modules require intelligent control and real-time power monitoring to support rapid current changes during high-speed operation. To handle fast load transients, the power supply must respond quickly while maintaining stable output regulation across input voltage and load variations. High-efficiency conversion reduces total server power loss and heat generation, while low output ripple helps improve signal integrity and system stability in high-density server platforms.

### 1.2 Size Constraints in Highly Integrated Designs

For high-density POL applications, such as EDSFF SSD modules, server backplane power modules, and storage expansion cards, the power solution must balance compact size, thermal performance, and power delivery capability. This is especially important when the available component height is limited, in some cases to less than 2 mm.

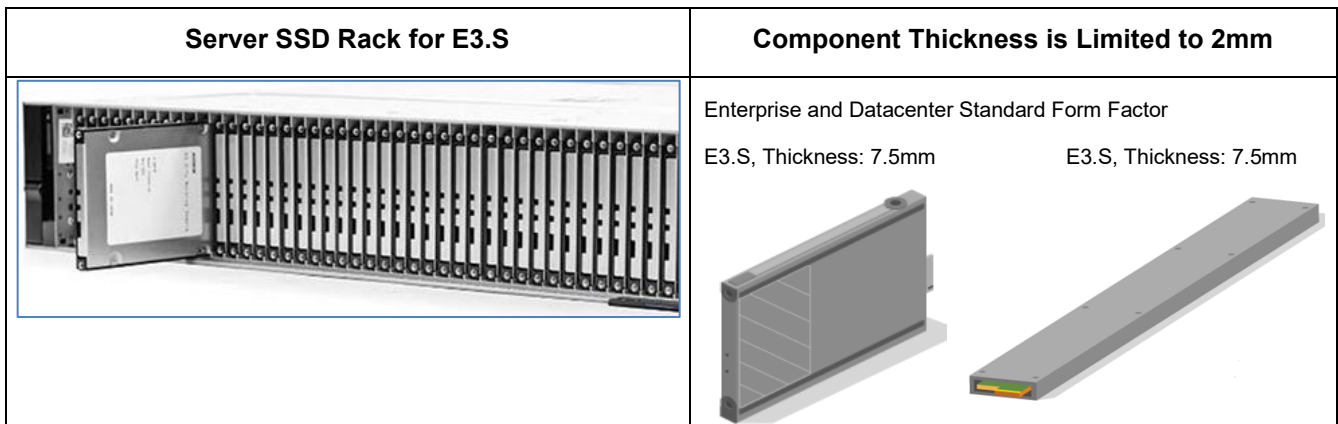

## 2 Control Topology Selection Based on System Requirements

To address the requirements for fast transient response, high power density, and high efficiency, Richtek introduces the [RTQ2811A](#) multiphase buck controller for server SSD and POL power applications. The [RTQ2811A](#) incorporates a flexible control topology that allows designers to select Dual-Phase, Two-Channel, or Parallel control by adjusting an external resistor. This flexibility enables the power design to be optimized for different current levels, rail configurations, and system architectures.

Designed for space-constrained applications with strict power and thermal requirements, the [RTQ2811A](#) delivers high efficiency, fast transient response, low output ripple, and stable power delivery.

### 2.1 Dual-Phase Control

The dual-phase control operates two phases with 180° interleaving to reduce the inductor current ripple. This provides the following benefits:

- [Reduced Output Capacitor Requirements](#)
- [Fast Transient Response](#)
- [Balanced Current Sharing](#)
- [High Flexibility](#)

#### 2.1.1 Reduced Output Capacitor Requirements

The interleaved inductor current waveforms double the effective output ripple frequency relative to the switching frequency, reducing output voltage ripple and input capacitor root mean square (RMS) current. This enables the use of smaller or fewer output capacitors.

#### 2.1.2 Fast Transient Response

Dual-phase interleaving compensates for current changes during sudden load steps, reducing output voltage droop and recovery time while improving overall system stability.

#### 2.1.3 Balanced Current Sharing

The output current is distributed between two phases, reducing current stress on each inductor and the high-side and low-side MOSFETs. This helps reduce component temperature rise and improves long-term reliability.

#### 2.1.4 High Flexibility

This topology is optimized for server SSD and POL applications requiring high current delivery and fast transient response, while achieving an optimal tradeoff among power density, conversion efficiency, and system reliability.

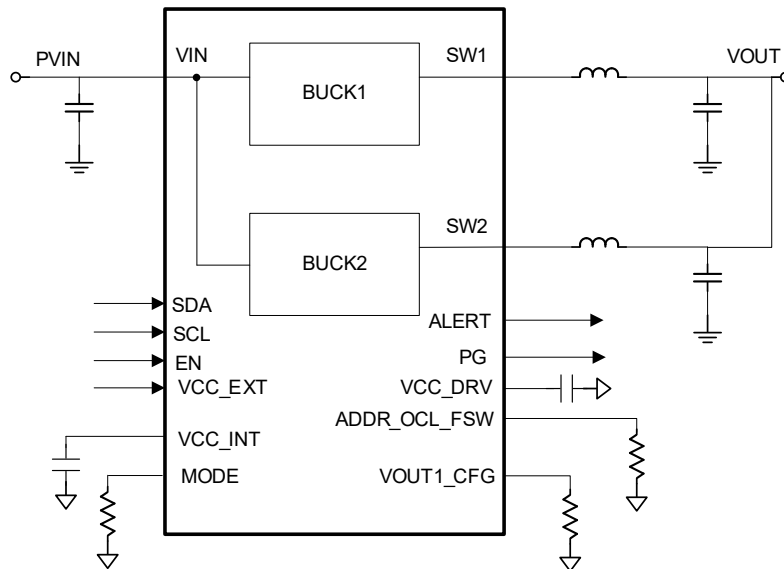

Figure 1. Dual-Phase Control

## 2.2 Two-Channel Control

The two-channel control provides two fully independent power outputs. Since interleaving control and current sharing are not required, the control implementation is simplified and overall design complexity is reduced. This topology is well suited for applications requiring multiple independent power rails with moderate current demand, such as storage controllers, memory modules, and partitioned peripheral power systems.

Each output channel operates independently, without cross-channel interference, providing greater power distribution flexibility and simplified system power management. Key features include:

- Simple Structure and Easy Implementation
- BOM Cost Advantage
- Flexible Power Sequencing

### 2.2.1 Simple Structure and Easy Implementation

Eliminating the requirement for interleaved timing control and current sharing simplifies circuit implementation and reduces design validation complexity.

### 2.2.2 BOM Cost Advantage

The simple architecture reduces component requirements and lowers overall BOM cost.

### 2.2.3 Flexible Power Sequencing

Two-channel integration allows designers to configure rail timing based on system requirements, making the device suitable for applications with defined power sequencing needs.

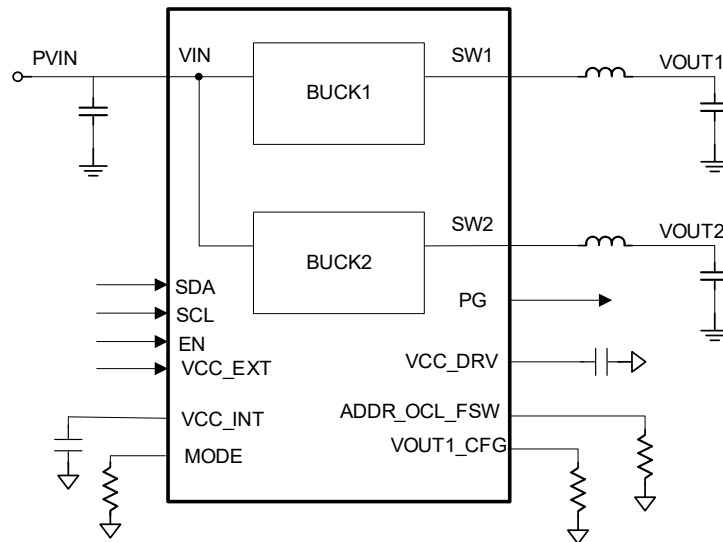

Figure 2. Two-Channel Control

## 2.3 Parallel Control

Compared to the dual-phase control, the parallel control simplifies hardware implementation and reduces overall system cost. However, the lack of phase interleaving results in comparatively lower EMI and transient performance. As a result, this architecture is typically adopted in cost-sensitive applications with moderate performance requirements.

Key characteristics of parallel control architecture include:

- Fewer Inductors Required
- Simpler Control Method
- Lower Architecture Complexity

### 2.3.1 Fewer Inductors Required

Only a single inductor is required, which avoids the current imbalance that may occur when multiple inductors are connected in parallel.

### 2.3.2 Simpler Control Method

A single-phase controller can be implemented with additional MOSFETs connected in parallel to distribute the conduction current. This reduces the thermal stress on individual devices and helps simplify thermal management.

### 2.3.3 Lower Architecture Complexity

The simplified control reduces the complexity and helps streamline system design and debugging.

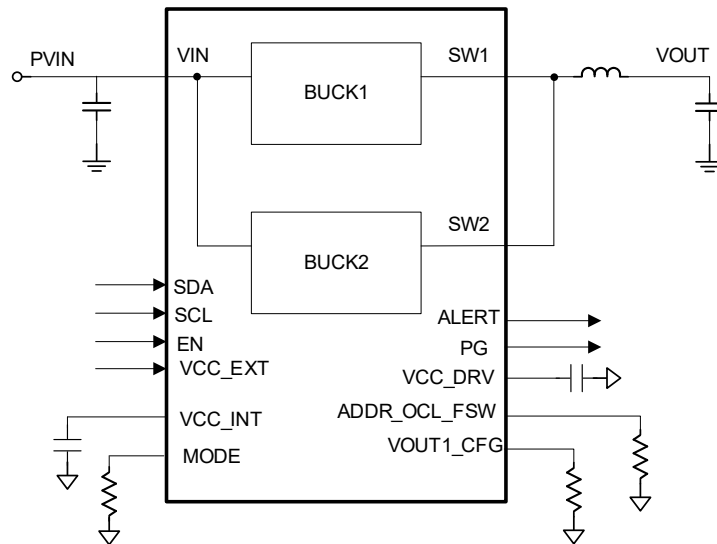

Figure 3. Parallel Control

**Table 1. Comparison of Control Topologies**

Control Topology	Dual-Phase	Two-Channel	Parallel
<b>Key Advantage</b>	Provides high current through one control loop to optimize efficiency	Provides two independent voltage outputs	Increases the output current limit at a lower cost
<b>Efficiency</b>	+++ (highest)	+(high)	++ (higher)
<b>Load Transient</b>	+++ (fastest)	++ (fast)	++ (fast)
<b>Output Ripple</b>	+++ (lowest)	++ (lower)	+(low)
<b>Switching Noise</b>	+++ (lowest)	++ (lower)	+(low)
<b>Output Current Capability</b>	+++ (best)	+(good)	++ (better)
<b>Cost Advantage</b>	+(good)	++ (better)	+++ (best)

## 3 Advantages of the Design Scheme

### 3.1 High-Precision, Low-Noise Power Control Topology

For high-accuracy voltage regulation, the [RTQ2811A](#) uses the A<sup>2</sup>RCOT (Adaptive Asynchronous Ripple Constant-On-Time) voltage feedback control topology, together with a high-precision reference and low-noise design, to maintain output voltage error within  $\pm 0.75\%$ . Built-in compensation and correction mechanisms reduce the impact of temperature drift and load variation on the output voltage, supporting the accuracy requirements of server SSD and POL power rails.

The following sections provide detailed information on the temperature characteristics, load regulation, and dynamic response capabilities. For more information regarding the A<sup>2</sup>RCOT voltage feedback control technology, refer to the product datasheet.

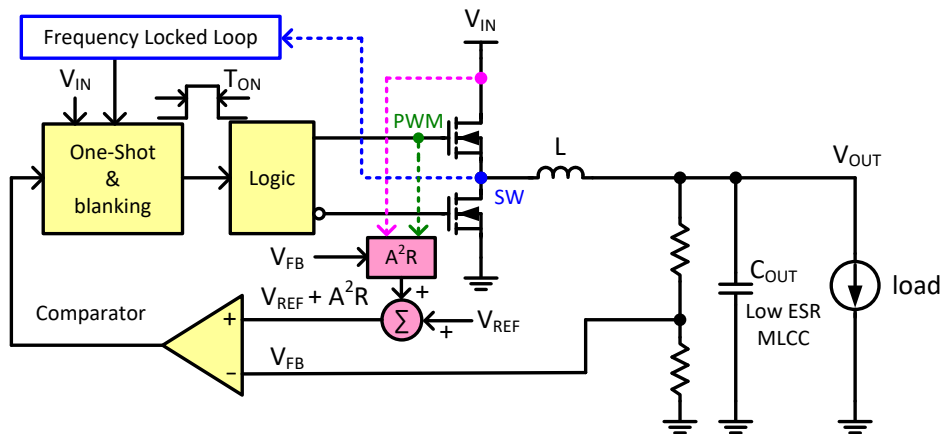

Figure 4. A<sup>2</sup>RCOT Control Loop

#### 3.1.1 Excellent Temperature Compensation

[Figure 5](#) and [Figure 6](#) illustrate the [RTQ2811A](#) output voltage characteristics under different temperature conditions. For server SSD and POL applications, voltage stability across temperature variation is critical, as these systems are typically required to operate continuously under wide operating temperature ranges. Even minor voltage deviations may impact data integrity and overall system reliability.

Across the operating temperature range from  $-40^{\circ}\text{C}$  to  $85^{\circ}\text{C}$ , the [RTQ2811A](#) maintains a highly stable output voltage profile, with output deviation controlled within  $\pm 0.75\%$ . The final specification reference for the  $\pm 0.75\%$  accuracy target should be confirmed based on product specifications, customer requirements, or applicable server platform standards.

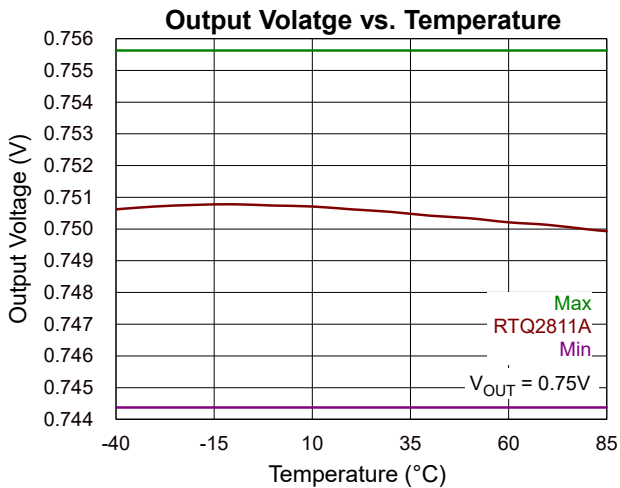

Figure 5. Output Voltage  $V_{OUT} = 0.75V$  versus Temperature Change

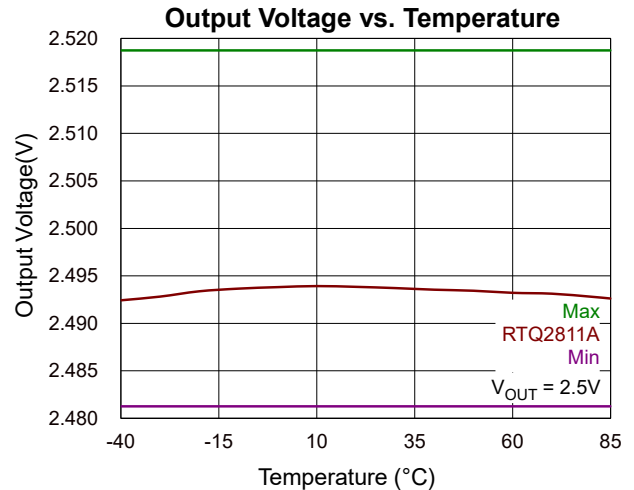

Figure 6. Output Voltage  $V_{OUT} = 2.5V$  versus Temperature Change

### 3.1.2 Accurate Output Voltage Regulation

Figure 7 and Figure 8 compare the RTQ2811A output voltage characteristics under different load conditions. In server SSD and POL applications, the power solution must maintain accurate and stable output voltage during dynamic load changes. Excessive voltage variation may cause data transmission errors, system instability, or reduced server performance.

With load conditions ranging from single-phase output up to 12A to dual-phase output up to 24A, the RTQ2811A maintains a smooth and stable output voltage profile, with deviation kept within the  $\pm 0.75\%$  output accuracy target.

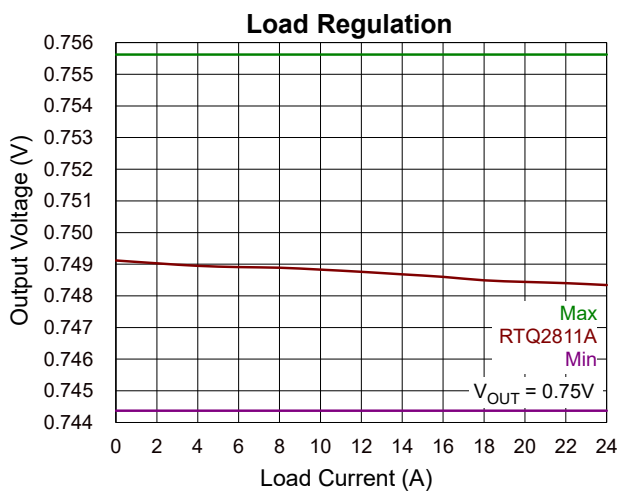

Figure 7. Load and Output  $V_{OUT} = 0.75V$  Variation

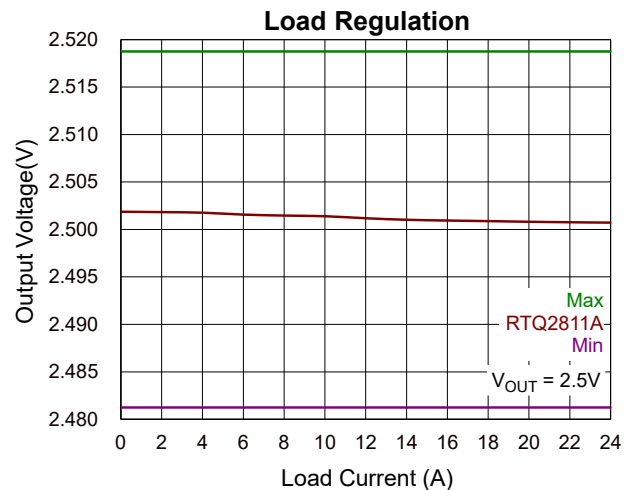

Figure 8. Load and Output  $V_{OUT} = 2.5V$  Variation

### 3.1.3 Fast Load Transient Response

The [RTQ2811A](#) incorporates advanced power control technology to provide stable power delivery during rapid load changes. Its fast compensation loop detects and responds to load transients quickly, reducing output voltage droop and recovery time. The device also includes output voltage overshoot suppression. When the system transitions to a light-load or no-load condition, the control loop responds by turning off the low-side MOSFET to help limit output voltage overshoot and prevent abnormal system operation.

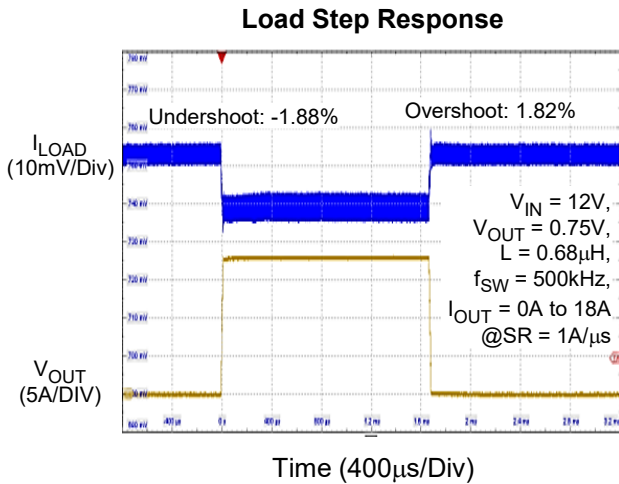

Figure 9. Load Step Response at  $V_{OUT} = 0.75V$

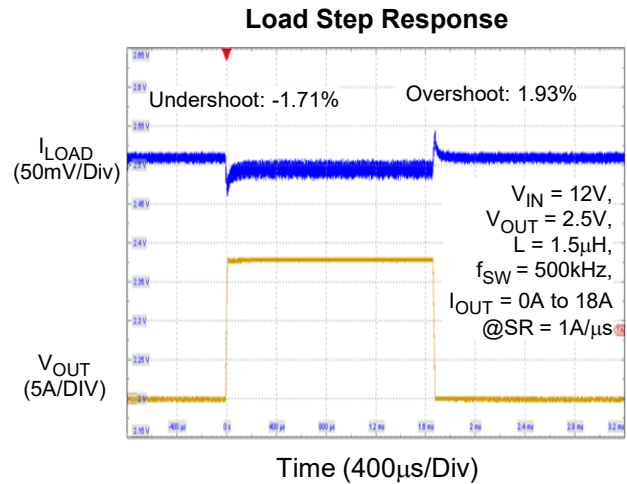

Figure 10. Load Step Response at  $V_{OUT} = 2.5V$

### 3.2 High Power Efficiency and Thermal Management

In server SSD and POL applications, power efficiency directly impacts system power consumption, thermal management, and overall operating cost. The [RTQ2811A](#) utilizes high-efficiency synchronous rectification to achieve conversion efficiency exceeding 90%, reducing both power loss and heat generation. Integrated ADC temperature monitoring and over-temperature protection further ensure stable operation under high-load conditions, improving overall system reliability and component lifetime.

As shown in [Figure 11](#) and [Figure 12](#), the [RTQ2811A](#) achieves high efficiency through optimized circuit architecture and process technology. Improved efficiency reduces server power dissipation, minimize thermal stress, and simplify thermal management design.

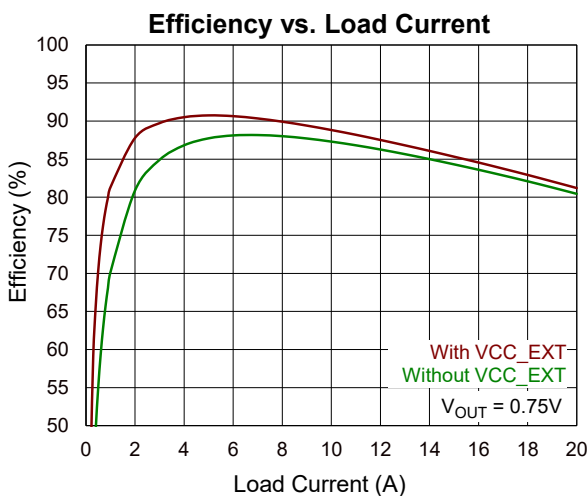

Figure 11. Efficiency Diagram at  $V_{OUT} = 0.75V$

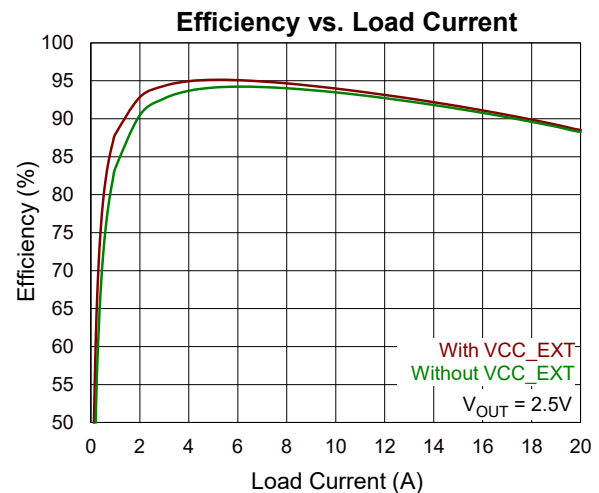

Figure 12. Efficiency Diagram at  $V_{OUT} = 2.5V$

## 3.2.1 High-Temperature Warning and Reporting

The [RTQ2811A](#) supports temperature reporting and allows the high-temperature warning threshold to be configured through I<sup>2</sup>C. The warning function can be set to activate from 100°C, helping the system detect thermal risk early and maintain safe operation across different application environments.

## 3.2.2 Over-Temperature Protection

The [RTQ2811A](#) includes over-temperature protection with an I<sup>2</sup>C-configurable threshold. At the lowest setting, over-temperature protection is triggered when the temperature exceeds 125°C. The device then shuts down all output rails and reports the fault through the ALERT signal. This helps prevent thermal damage and enables real-time system health monitoring.

## 3.3 ADC Detection and Monitoring

The [RTQ2811A](#) integrates an ADC that measures external input voltage ( $V_{IN}$ ), output voltage ( $V_{OUT}$ ), output current ( $I_{OUT}$ ), and IC temperature. These values can be read through I<sup>2</sup>C. Continuous ADC sampling enables real-time monitoring of  $V_{IN}$ ,  $V_{OUT}$ ,  $I_{OUT}$ , and IC temperature, allowing the system to track operating status and respond to abnormal conditions.

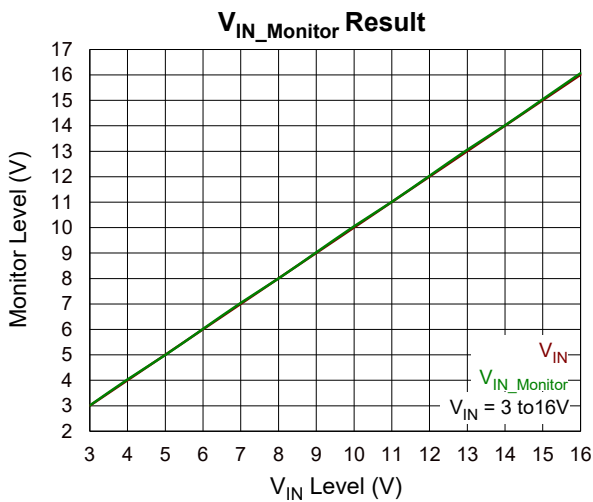

Figure 13. ADC Detection and Management of  $V_{IN}$

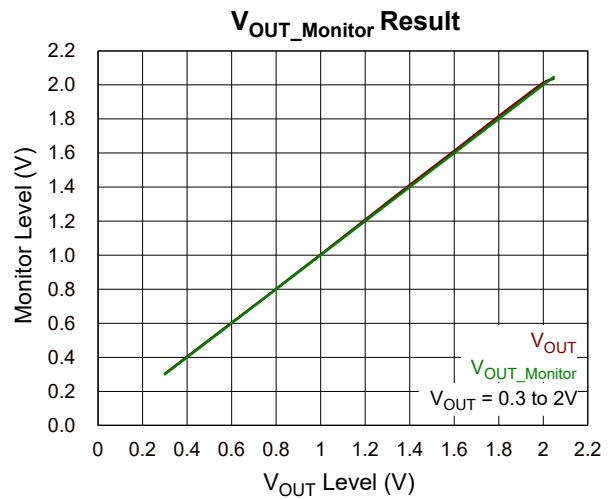

Figure 14. ADC Detection and Management of  $V_{OUT}$

## 4 Conclusion

The [RTQ2811A](#) is designed for data center server SSDs and POL power modules, integrating high efficiency, intelligent monitoring, programmable control, and flexible architecture options to deliver stable and reliable power in high-density, high-transient-load environments.

In addition to meeting the power requirements of current server and storage platforms, the [RTQ2811A](#) addresses the design challenges of next-generation high-performance computing and storage architectures. Its flexible configuration and monitoring functions improve power design scalability and system reliability.

Richtek continues to strengthen its power management expertise by combining server platform experience with ongoing product innovation, helping data centers improve system performance, power efficiency, and operational stability.

To stay informed with more information about our products, please [subscribe to our newsletter](#).

### **Richtek Technology Corporation**

14F, No. 8, Tai Yuen 1st Street, Chupei City

Hsinchu, Taiwan, R.O.C.

Tel: 886-3-5526789

Richtek products are sold by description only. Richtek reserves the right to change the circuitry and/or specifications without notice at any time. Customers should obtain the latest relevant information and data sheets before placing orders and should verify that such information is current and complete. Richtek cannot assume responsibility for use of any circuitry other than circuitry entirely embodied in a Richtek product. Information furnished by Richtek is believed to be accurate and reliable. However, no responsibility is assumed by Richtek or its subsidiaries for its use; nor for any infringements of patents or other rights of third parties which may result from its use. No license is granted by implication or otherwise under any patent or patent rights of Richtek or its subsidiaries.

---

Copyright © 2026 Richtek Technology Corporation. All rights reserved. **RICHTEK** is a registered trademark of Richtek Technology Corporation.