

Boost Converter Design Insights: Richtek's Popular Product Key Features and Design Examples

Kurt Lee, Sophia Tong | AN087

Richtek offers a diverse range of boost converter solutions to meet various application requirements. This application note explores the key features and application examples of popular boost converters, assisting engineers in selecting the most suitable product to ensure high efficiency and system stability.

Table of Contents

1	Design Considerations for Selecting a Boost Converter	2
2	Application Examples of Different Boost Converters	2
2.1	Bypass Switch Integrated with I ² C Control – RT4803/RT4803A/RT4803B Series	2
2.2	Low Quiescent Current – RT4823	3
2.3	Easy Design – RT4812.....	3
2.4	High-Output Capability – RT8581	4
3	Conclusion	5

1 Design Considerations for Selecting a Boost Converter

Selecting an appropriate boost converter requires evaluating multiple factors, including input and output voltage range, quiescent current, power capacity, control interface, packaging, and cost. Richtek's boost converter portfolio can be categorized into four major types based on functionality: Bypass Switch Integrated with I²C Control – [RT4803/RT4803A/RT4803B](#) Series, Low Quiescent Current – [RT4823](#), Easy Design – [RT4812](#) and High-Output Capability – [RT8581](#).

	With Bypass MOSFET			Easy Design	Low Iq	High Vout
	RT4803	RT4803A	RT4803B	RT4812	RT4823	RT8581
Vin	1.8V-5.5V	1.8V-5V	1.8V-5V	1.8V-5V	1.8V-5.5V	2.7V-12V
Vout	2.85V-4.4V	2.85V-4.4V	2.85V-4.4V	1.8V-5.5V	5V	4.5V-12.6V
I/O	1.8V	1.8V	1.2V	1.8V	1.8V	1.2V
ISW	5A	4A	4A	4A	2.15A	10A
BYP_FET	Y	Y	Y	--	--	--
I ² C	Y	Y	Y	--	--	--
Iq	65μA	55μA	56μA	90μA	4μA	30μA
Packages	WL-CSP1.67x1.67-16(BSC)	WL-CSP1.67x1.67-16(BSC)	WL-CSP1.67x1.67-16(BSC)	TSOT-23-8(FC)	WL-CSP1.3x1.2-9(BSC)	VQFN2x2.5-11

2 Application Examples of Different Boost Converters

2.1 Bypass Switch Integrated with I²C Control – RT4803/RT4803A/RT4803B Series

In a conventional boost converter operating in Bypass Mode, current flows from the input to the output through the inductor and high-side switch, resulting in higher conduction losses due to the resistance of the inductor. In contrast, the [RT4803](#) series allows current to flow directly through the bypass switch to the output, bypassing the inductor, and eliminating DCR losses. This can effectively reduce conduction loss. This enhancement improves efficiency from the conventional 97 to 98% to nearly 100%, reducing power losses and minimizing heat dissipation.

The [RT4803B](#), housed in a compact CSP package, supports I/O voltage as low as 1.2V, making it ideal for silicon anode batteries (Si-Anode battery) used in mobile modules such as 2G PA, WiFi modules, audio amplifiers, and other portable or wearable devices.

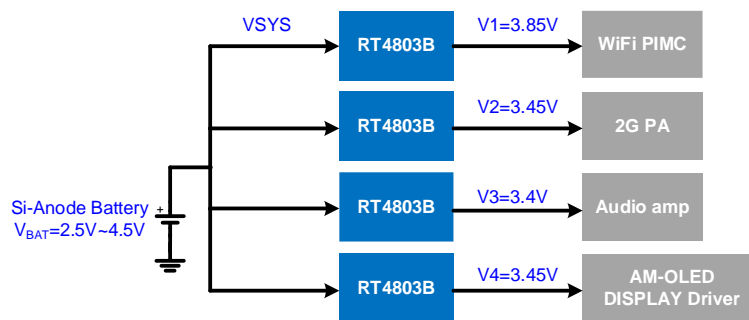

Figure 1. Mobile Power Application Example

2.2 Low Quiescent Current – RT4823

The [RT4823](#), also in a CSP package, is designed for portable and wearable devices. For example, in On-The-Go (OTG) functionality, when a user connects peripherals like a small fan, storage device, or flashlight to the USB port, the mobile device must provide 5V output at 1.5A (7.5W) per the Type-C standard. The [RT4823](#) meets this requirement while featuring only 4μA of quiescent current, making it ideal for long standby applications. Additionally, it features reverse blocking protection, preventing external voltage from flowing back to the input, enhancing system stability.

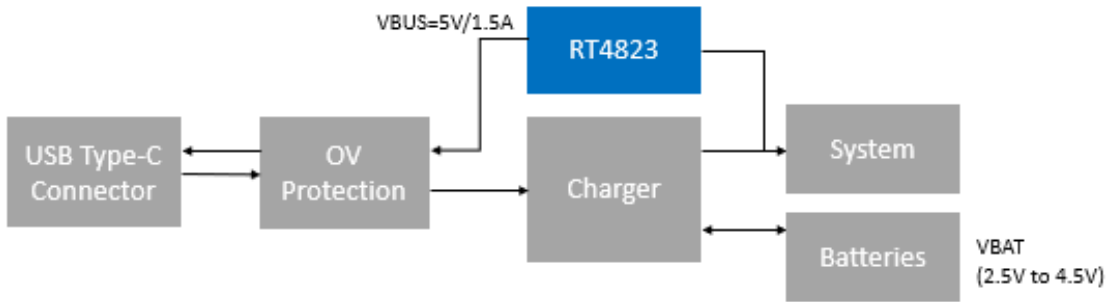

Figure 2. OTG Application Example

2.3 Easy Design – RT4812

The [RT4812](#) is a high-efficiency boost converter housed in a TSOT-23-8 package. It offers a flexible output voltage adjustment via the FB pin and allows setting the output current limit to 1A or 2.1A through pin configuration. With a cost-effective TSOT-23-8 package that eliminates the requirements for PCB vias, the [RT4812](#) is ideal for cost-sensitive applications on single or double-layer PCB boards, such as power bank, wireless mice and other consumer electronic devices.

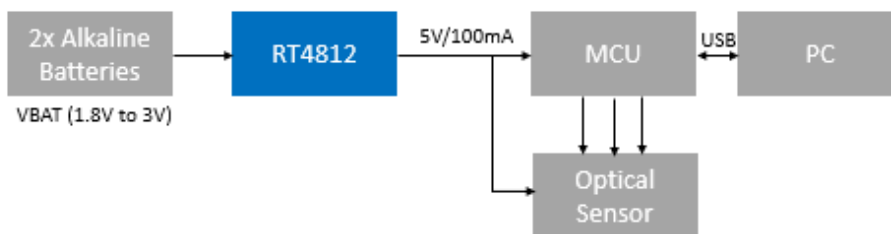

Figure 3. Optical Mouse Application

2.4 High-Output Capability – RT8581

The [RT8581](#) is a high-output-voltage boost converter that provides an efficient and compact power solution for systems with lithium-ion batteries, delivering up to 20W of power output. The RT8581 can deliver a stable output voltage from a single lithium-ion battery, with internal switching components featuring low on-resistance, achieving high efficiency of up to 94.5% ($V_{in} = 5V$, $V_{out} = 12V$, $I_{out} = 1.5A$). Figure 4 illustrates the application of the RT8581 in powering NAND Flash. By supplying VPP through the [RT8581](#), the write speed of NAND Flash can be effectively improved, optimizing storage performance and enhancing overall system efficiency. In addition, the [RT8581](#) can also power 9W to 15W audio amplifiers, as shown in Figure 5.

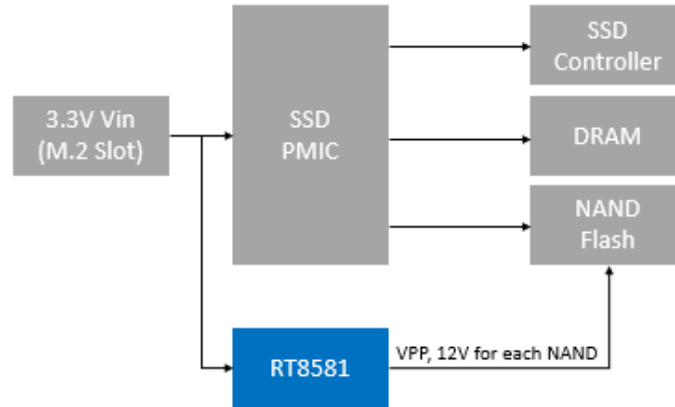

Figure 4. NAND Flash Power Supply Example

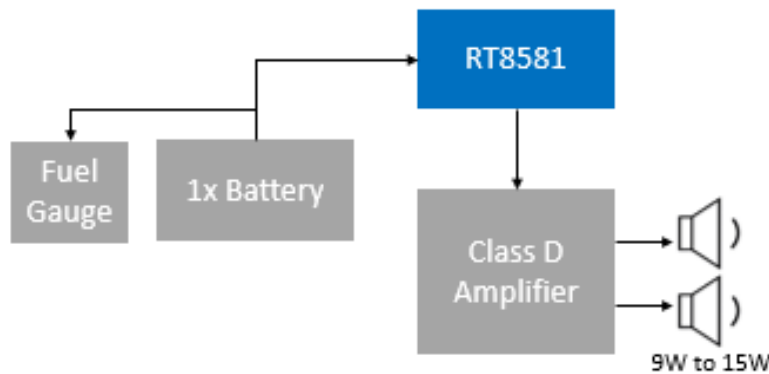

Figure 5. Audio Amplifier Application

3 Conclusion

Richtek offers a diverse range of boost converters to meet the requirements of various applications in terms of power efficiency, quiescent current, package size, and control interface. This application note provides an overview of the characteristics and application examples of different boost converters, assisting engineers in selecting the most suitable solution. The [RT4803](#) series with a bypass switch reduces conduction losses and improves efficiency. The [RT4823](#) with low quiescent current is ideal for OTG and long standby applications. The [RT4812](#) offers a cost-efficient for easy designs, while the [RT8581](#) provides high-output-capacity for applications like NAND Flash and audio amplifiers. These solutions enable engineers to achieve optimal power management with the best balance between high performance and low power consumption.

To stay informed with more information about our products, please [subscribe to our newsletter](#).

Richtek Technology Corporation

14F, No. 8, Tai Yuen 1st Street, Chupei City

Hsinchu, Taiwan, R.O.C.

Tel: 886-3-5526789

Richtek products are sold by description only. Richtek reserves the right to change the circuitry and/or specifications without notice at any time. Customers should obtain the latest relevant information and data sheets before placing orders and should verify that such information is current and complete. Richtek cannot assume responsibility for use of any circuitry other than circuitry entirely embodied in a Richtek product. Information furnished by Richtek is believed to be accurate and reliable. However, no responsibility is assumed by Richtek or its subsidiaries for its use; nor for any infringements of patents or other rights of third parties which may result from its use. No license is granted by implication or otherwise under any patent or patent rights of Richtek or its subsidiaries.