

2.95V to 6V Input, 3A Output, 2MHz, Synchronous Step-Down Converter

Purpose

The RT2613A is a synchronous step-down converter with the input voltage range from 2.95V to 6V and provides 3A output current. This document explains the function and use of the RT2613A evaluation board (EVB), and provides information to enable operation, modification of the evaluation board and circuit to suit individual requirements.

Table of Contents

Purpose	1
Introduction.....	2
Key Performance Summary Table	2
Bench Test Setup Conditions	3
Schematic, Bill of Materials & Board Layout	5
More Information.....	7
Important Notice for Richtek Evaluation Board	7

Introduction

General Product Information

The RT2613A is a high efficiency step-down converter and capable of delivering 3A output current over a wide input voltage range from 2.95V to 6V. The RT2613A provides accurate regulation for a variety of loads with $\pm 3\%$ accuracy. For reducing inductor size, it provides up to 2MHz switching frequency. The efficiency is maximized through the integrated 45m Ω MOSFETs and 550 μ A typical supply current. Under voltage lockout voltage of the RT2613A is 2.7V, and it also provides external setting by a resistor network on the enable pin. The RT2613A provides protections such as inductor current limit under voltage lockout and thermal shutdown. The over temperature threshold is 145°C. The RT2613A is available in WQFN-16L 3x3 package.

Product Feature

- Integrated 45m Ω MOSFETs
- Input Range : 2.95V to 6V
- Adjustable PWM Frequency : 700kHz to 2MHz
- Output Current : 3A
- 95% Efficiency
- Adjustable Soft-Start
- Power Good Indicator
- Enable Control
- Under Voltage Lockout
- Current Limit
- Thermal Shutdown

Key Performance Summary Table

Key Features	Evaluation Board Number : PCB038_V1
Input Voltage Range	2.95V to 6V
Max Output Current	3A
Default Output Voltage	1.8V
Default Marking & Package Type	RT2613AGQW, WQFN-16L 3x3
Operation Frequency	Adjustable from 700kHz to 2MHz

Bench Test Setup Conditions

Headers Description and Placement

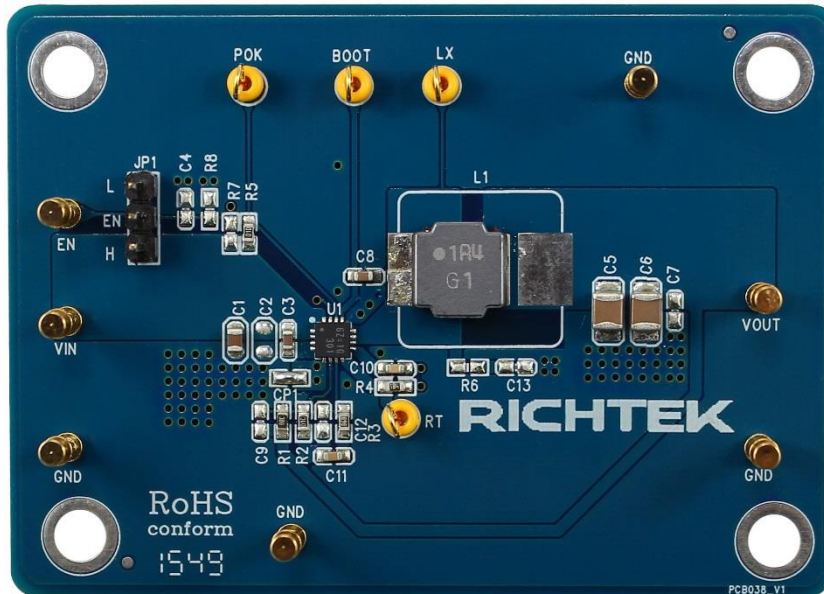

Please carefully inspect the EVB IC and external components, comparing them to the following Bill of Materials, to ensure that all components are installed and undamaged. If any components are missing or damaged during transportation, please contact the distributor or send e-mail to evb_service@richtek.com

Test Points

The EVB is provided with the test points and pin names listed in the table below.

Test point/ Pin name	Signal	Comment (expected waveforms or voltage levels on test points)
VIN	Input voltage	Power input.
EN	Enable test point	Externally pulled high to enable and pulled low to disable this chip. It is internally pulled up to high when the pin is floating.
GND	Ground	The exposed pad must be soldered to a large PCB and connected to GND for maximum power dissipation.
AGND	Analog ground	Analog ground.
COMP	Compensation node test point	Compensation node for converter stability.
FB	Feedback voltage input	Feedback input.
PGOOD	Power good test point	Output of power good indicator.
BOOT	Bootstrap supply test point	Bootstrap supply for high-side gate driver. Connect a capacitor between the BOOT and LX pins.
LX	Switch node test point	Connect this pin to an external L-C filter.
RT/SYNC	Clock input	Frequency Setting and External Synchronous.

Power-up & Measurement Procedure

1. Apply a 12V nominal input power supply ($2.95V < V_{IN} < 6V$) to the VIN and GND terminals.
2. Set the jumper at JP1 to connect terminals 1 and 2, connecting EN to enable operation.
3. Verify the output voltage (approximately 1.8V) between VOUT and GND.
4. Connect an external load up to 3A to the VOUT and GND terminals and verify the output voltage and current.

Output Voltage Setting

Set the output voltage with the resistive divider (R1, R2) between VOUT and GND with the midpoint connected to FB. The output is set by the following formula :

$$V_{OUT} = 0.827 \times \left(1 + \frac{R1}{R2}\right)$$

Schematic, Bill of Materials & Board Layout

EVB Schematic Diagram

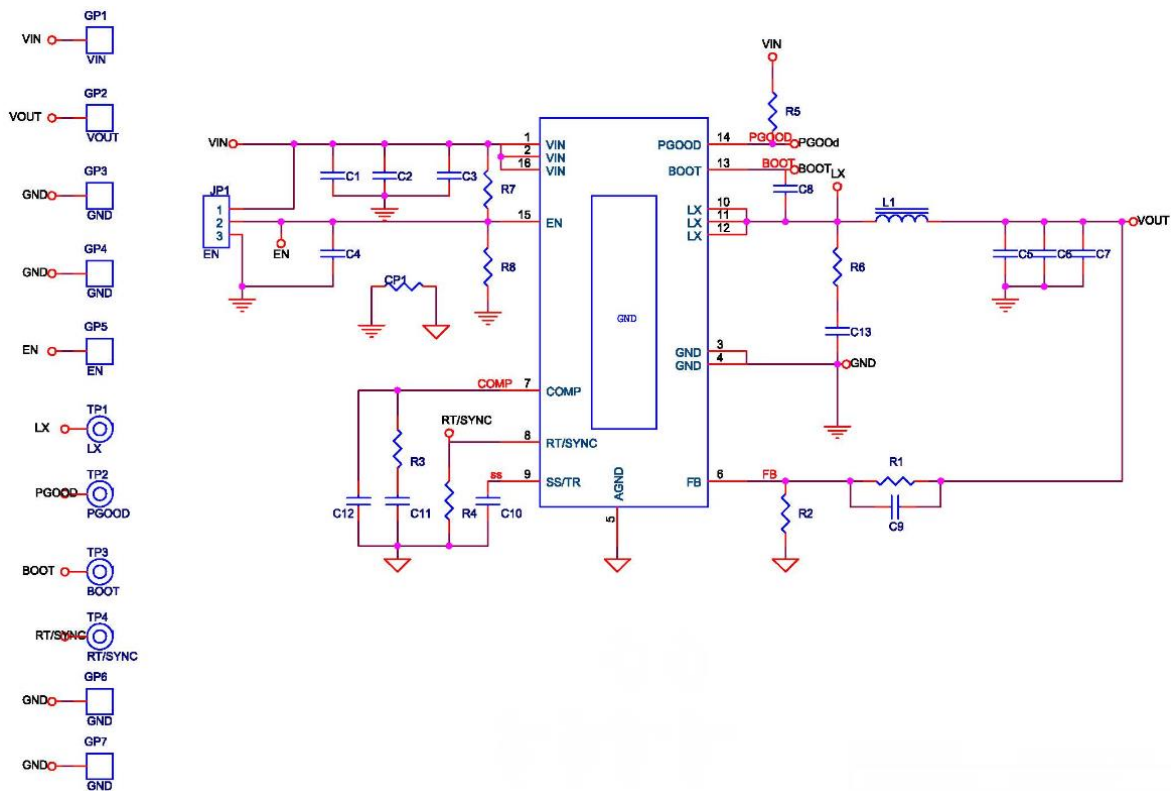

Bill of Materials

Reference	Qty	Part Number	Description	Package	Manufacture
U1	1	RT2613AGQW	DC/DC Converter	WQFN-16L 3x3	RICHTEK
C1	1	C2012X5R1C106KT	10 μ F/16V/X5R	C-0805	TDK
C3	1	C1608X5R1E105KT000E	1 μ F/25V/X5R	C-0603	TDK
C5, C6	2	GRM32ER61C226KE20L	22 μ F/16V/X7R	C-1210	MURATA
C8	1	C1608X7R1H104KT000N	0.1 μ F/50V/X7R	C-0603	TDK
C10	1	0603B103K500	10nF/50V/X7R	C-0603	WALSIN
C11	1	0603B332K500	3.3nF/50V/X7R	R-0603	WALSIN
L1	1	NR8040T1R4N	1.4 μ H/7A	8 x 8 x 4 mm	Taiyo Yuden
R1	1		11.8k	R-0603	
R2	1		10k	R-0603	
R3	1		7.68k	R-0603	
R4	1		180k	R-0603	
R5	1		100k	R-0603	
C2, C4, C7, C9, C12, C13, R6, R7, R8	9		NC		
CP1	1		0		

PCB Layout

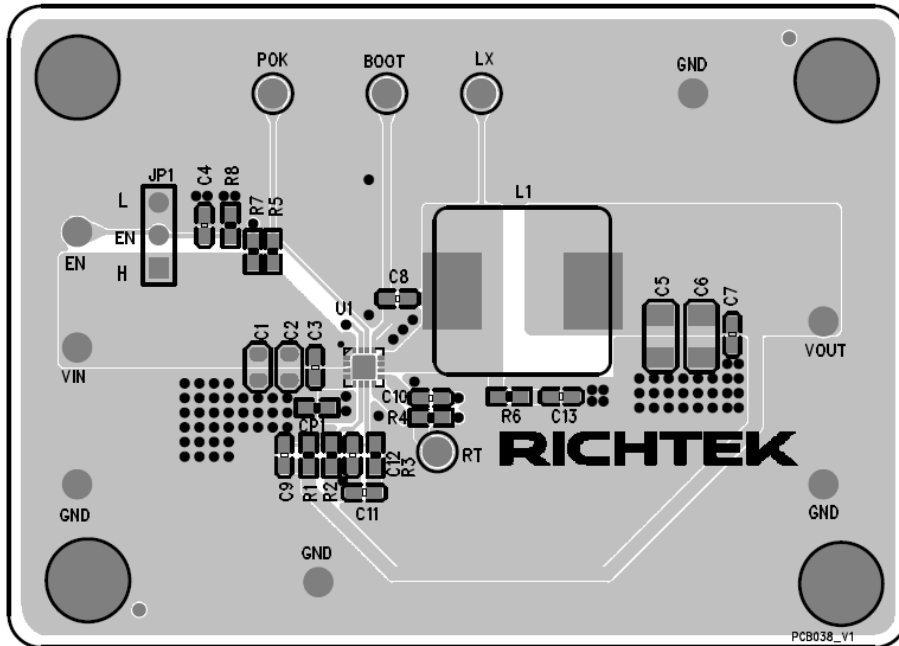

Top View (1st layer)

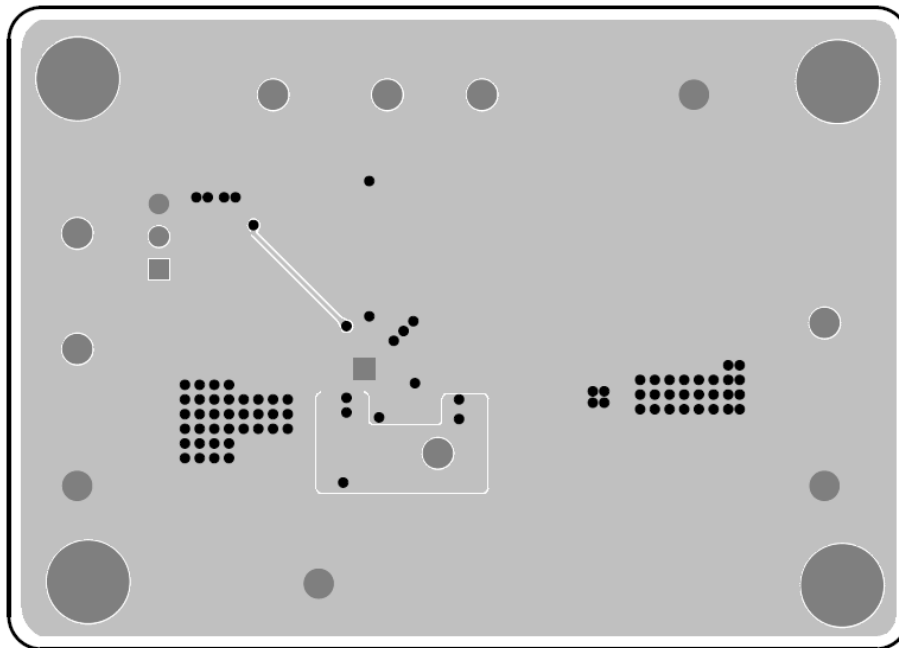

Bottom View (4th Layer)

More Information

For more information, please find the related datasheet or application notes from Richtek website <http://www.richtek.com>.

Important Notice for Richtek Evaluation Board

THIS DOCUMENT IS FOR REFERENCE ONLY, NOTHING CONTAINED IN THIS DOCUMENT SHALL BE CONSTRUED AS RICHTEK'S WARRANTY, EXPRESS OR IMPLIED, UNDER CONTRACT, TORT OR STATUTORY, WITH RESPECT TO THE PRESENTATION HEREIN. IN NO EVENT SHALL RICHTEK BE LIABLE TO BUYER OR USER FOR ANY AND ALL DAMAGES INCLUDING WITHOUT LIMITATION TO DIRECT, INDIRECT, SPECIAL, PUNITIVE OR CONSEQUENTIAL DAMAGES.